

The Southern Cross “Z” Model Windmill

The “Z” Model Southern Cross was originally designed in 1930, and first produced in 1931. It took its design from the 602 model Aermotor (refer Rob Laurent’s book – Southern Cross Engines page 236). There were a number of “Z” Models; the original a “Square Body design, of which there were two variations and then the later “Round Body” style.

The “Z” Pattern was made in 5 sizes, each designated by a double letter prefix – a 6ft is “ZA”, an 8ft is “ZB”, a 10ft is “ZC”, a 12ft is “ZD”, and a 14ft is “ZE” This is then followed by a 3 digit number. The Main Casting for a 6ft is therefore a “ZA001”

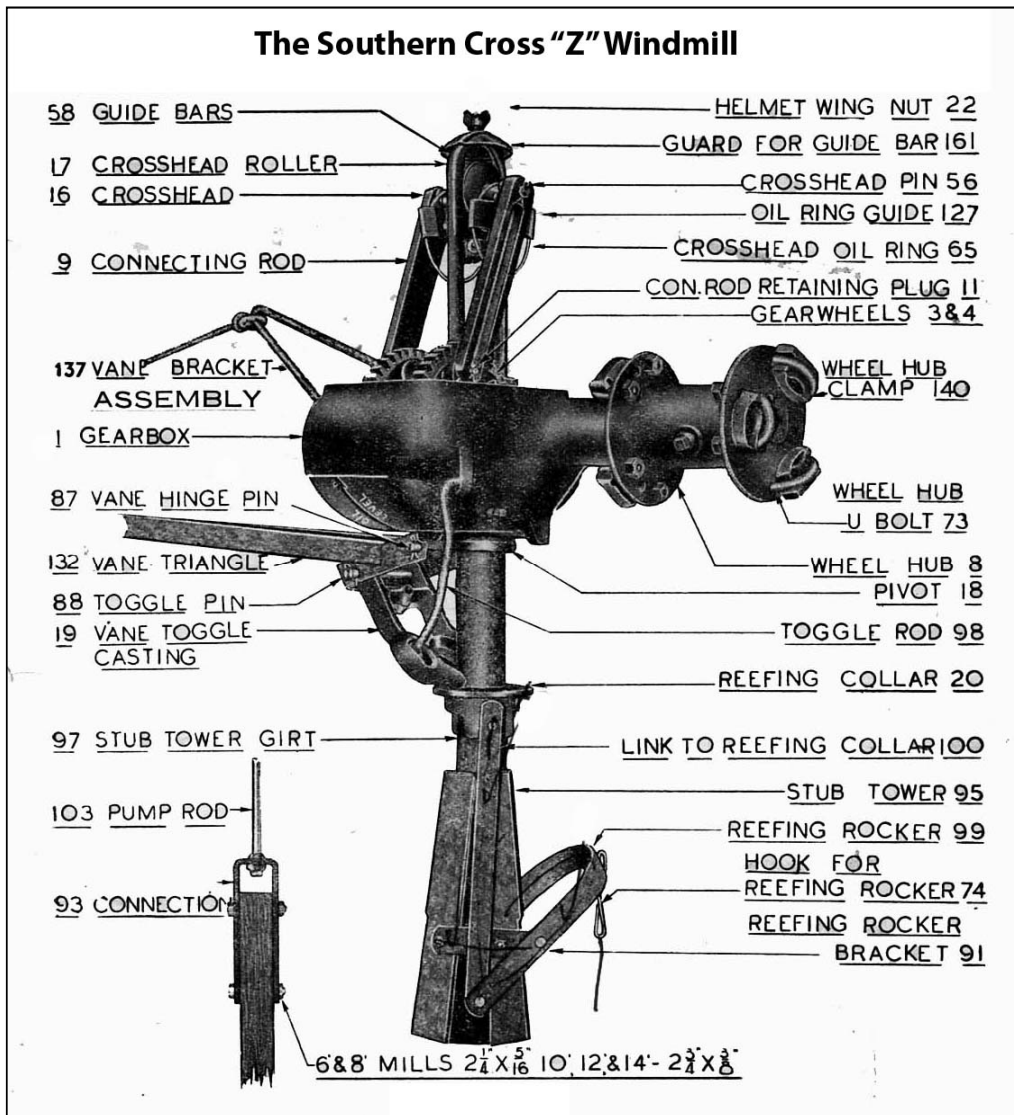

The Southern Cross “Z” Model Windmill

There are at least three variations of the “Z” model Southern Cross Windmill. These are definitely three different bodies or Main Castings, and there are two types of Hub – more variations come from different combinations of Hubs with Main Castings. The three variations of Main Casting are

The **Square Body** Casting with a **Small Hole**.

The sides of the Main Casting are distinctly square or upright. The hole that the Pump Rod runs through is only large enough for the pumprod; the Pivot Tube does not protrude through the casing.

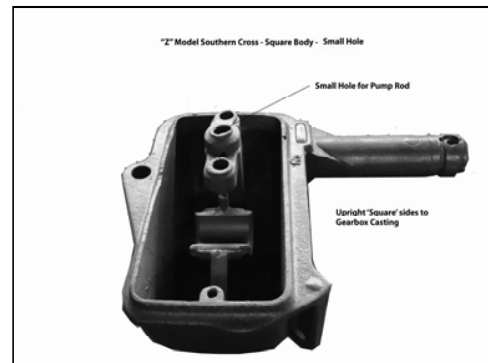

The **Square Body** Casting with a **Large Hole**

Again the sides are distinctly square or upright. However the hole that the Pump Rod runs through is large enough for the Pivot Tube to protrude through the casing.



The **Round Body** Casting

This is the most common of the “Z” models. Its sides have a definite roundness, a bulbous look, when viewed from the side (that is viewed from the side while the wind wheel is at the viewer’s right shoulder).

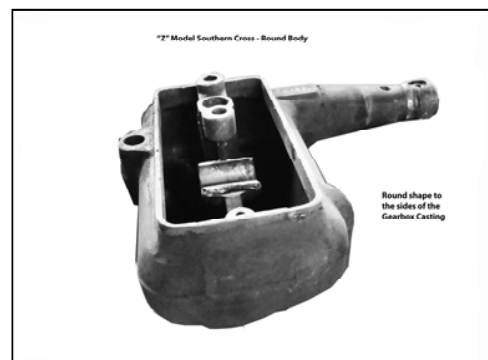

The two Hub variations are the Spider Hub and the Cottonreel Hub.

The **Spider Hub** is the older of the two. There were also some variations of these, but the differences are not significant. The version shown has a provision for a “U” Bolt to retain the Wheel Arms. In the older version of the Spider Hub, there was nothing holding the Wheel Arm, other than the tension of the Windwheel itself. The Wheel Arm was woven into the casting.



The **Cottonreel Hub** is the most common and is the latest of the models. This hub was also used for a time on the “IZ” Model when it was first released. The Wheel Arms are bolted to the flanges at the front and the back of the Hub, and retained using Cast Clamps and “U” Bolts. The Spider Hub was changed to the Cotton Reel Hub is about 1944



The Southern Cross "Z" Model Windmill

SOUTHERN CROSS 'Z' PATTERN WINDMILL (Genuine & Non-Genuine Parts)

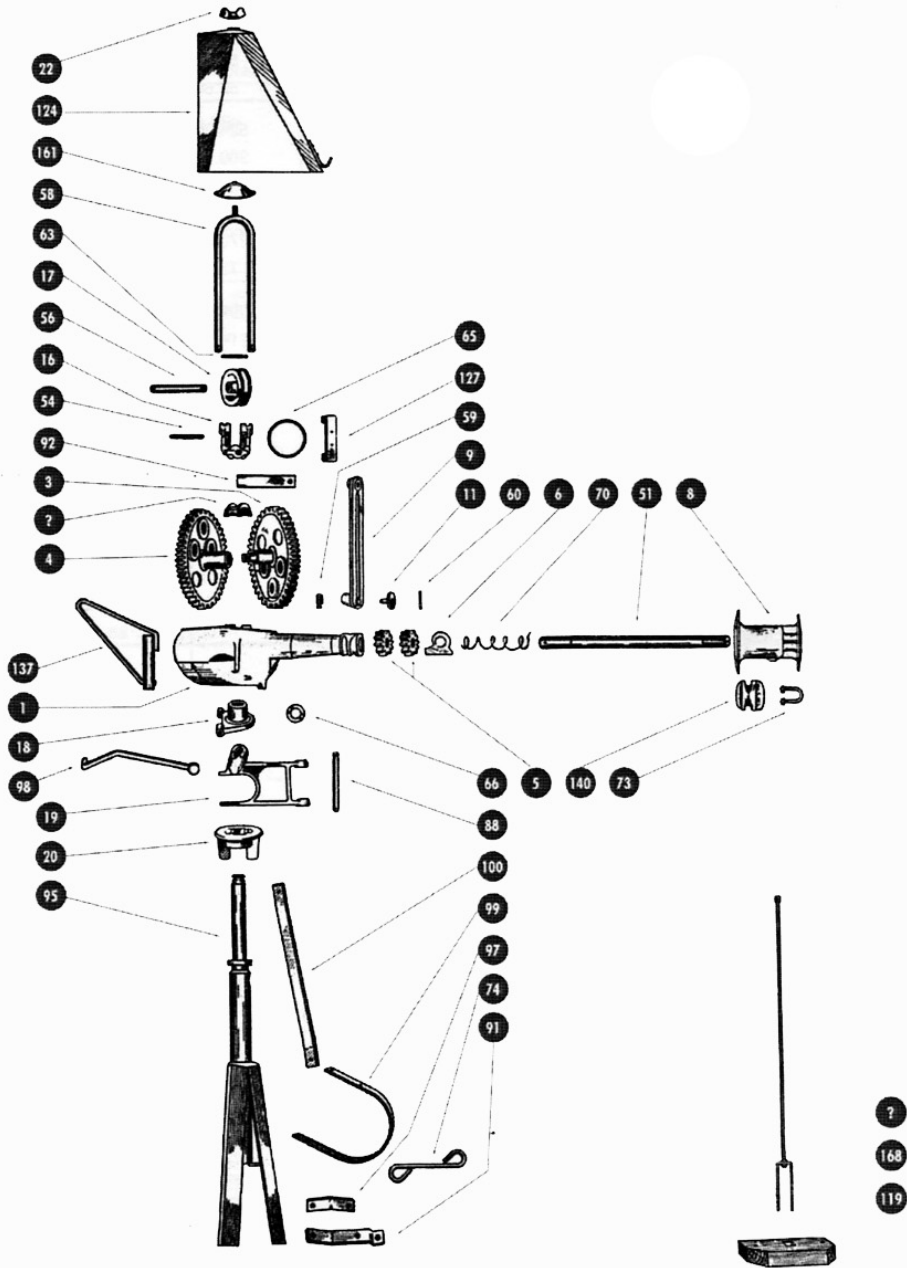

The Southern Cross “Z” Model Windmill

Part Description	6 ft	8 ft	10 ft	12 ft	14 ft
Gearbox Casting	ZA001	ZB001	ZC001	ZD001	ZE001
Large Gears (Pair)	ZA003	ZB003	ZC003	ZD003	ZD003
Pinion	ZA005	ZB005	ZC005	ZD005	ZE005
Oil Scraper	ZA006	ZB006	ZC006	ZD006	ZE006
Bearing Cap	ZA007	ZB007	ZC007	ZD007	ZD007
Wheel Hub & Shaft	ZA008	ZB008	ZC008	ZD008	ZE008
Connecting Rod	ZA009	ZB009	ZC009	ZD009	ZD009
Con. Rod Retaining Pin	ZA011	ZB011	ZC011	ZD011	ZD011
Crosshead w/- Oiling Rings	ZA018	ZB018	ZC018	ZD018	ZD018
Crosshead Roller	ZA017	ZB017	ZC017	ZD017	ZD017
Pivot	ZA018	ZB018	ZC018	ZD018	ZE018
Vane Toggle Casting	ZA019	ZB019	ZC019	ZD019	ZE019
Reefing Collar	ZA020	ZB020	ZC020	ZD020	ZE020
Helmet Wing Nut	ZA022	ZA022	ZA022	ZD022	ZD022
Pivot Tube Circlip	ZA025	ZB025	ZC025	ZD025	ZE025
Main Shaft	ZA051	ZB051	ZC051	ZD051	ZE051
Pump Rod Pin	ZA054	ZB054	ZC054	ZD054	ZD054
Brass Stud for Helmet	ZA055	ZB055	ZC055	ZD055	ZD055
Crosshead Pin	ZA056	ZB056	ZC056	ZD056	ZD056
Gulde Bar	ZA058	ZB058	ZC058	ZD058	ZD058
Oil Collector Peg	ZA059	ZB059	ZC059	ZD059	ZD059
Pinion Pin (set of 4)	ZA060	ZB060	ZC060	ZD060	ZD060
Gulde Bar Pin (set of 2)	ZA063	ZB063	ZC063	ZD063	ZD063
Oil Ring	ZA065	ZB065	ZC065	ZD065	ZD065
Turntable Washer	ZA066	ZB066	ZC066	ZD066	ZE066
Rivet for Reefing Rocker	ZA066	ZA066	ZC066	ZC066	ZC066
Rivet for Reefing Collar	ZA069	ZA069	ZC069	ZC069	ZC069
Main Shaft Oiling Spring	ZA070	ZB070	ZC070	ZD070	ZE070
Wheel Arm	ZA071	ZB071	ZC071	ZD071	ZE071
Hub “U” Bolt	ZA073a	ZB073a	ZC073a	ZD073a	ZD073a
“U” Bolt for Cast Clamp	ZA073b	ZB073b	ZC073b	ZD073b	ZD073b
Hook for Reefing Collar	ZA074	ZA074	ZC074	ZC074	ZC074
Inner Ring Bracket	ZA075	ZB075	ZC075	ZD075	ZD075
Outer Ring	ZA077	ZB077	ZC077	ZD077	ZE077
Inner Ring	ZA079	ZB079	ZC079	ZD079	ZE079
Outer Fan Bracket	ZA080	ZB080	ZC080	ZD080	ZD080
Fan	ZA082	ZB082	ZC082	ZD082	ZD082
Vane Hinge Pin	ZA087	ZB087	ZC087	ZD087	ZE087

The Southern Cross “Z” Model Windmill

Part Description	6 ft	8 ft	10 ft	12 ft	14 ft
Toggle Pin	ZA088	ZB088	ZC088	ZD088	ZE088
Vane Stay	ZA089	ZB089	ZC089	ZD089	ZE089
Reefing Rocker Bracket 3P	ZA091b	ZA091b	ZC091b	ZC091b	ZC091b
Reefing Rocker Bracket 4P	ZA091c	ZA091c	ZC091c	ZC091c	ZC091c
Gearwheel Bearing Clamp	ZA092	ZB092	ZC092	ZD092	ZD092
Mill Rod Connection	ZA093	ZB093	ZC093	ZD093	ZD093
Stub Tower – 3 Post	ZA095c	ZB095c	ZC095c	ZD095c	ZE095c
Stub Tower Girt – 3 Post	ZA097	ZA097	ZC097	ZC097	ZC097
Toggle Rod	ZA098	ZB098	ZC098	ZD098	ZE098
Reefing Rocker 3 Post	ZA099	ZB099	ZC099	ZD099	ZE099
Link for Reefing Collar	ZA100	ZB100	ZC100	ZD100	ZE100
Reefing Handle Clip	ZA101	ZA101	ZA101	ZD101a	ZD101a
Reefing Handle	ZA102	ZB102	ZC102	ZD102	ZD102
Pump Rod	ZA103	ZB103	ZC103	ZD103	ZD103
Reefing Handle Pin	ZA104	ZB104	ZC104	ZD104	ZD104
Reefing Handle Hook Bolt	ZA105	ZB105	ZC105	ZD105	ZE105
Furl Hook	ZA106	ZA106	ZA106	ZD106	ZD106
Reefing Handle Catch	ZA108b	ZA108b	ZA108b	ZA108b	ZA108b
Reefing Handle Collar	ZA111	ZA111	ZA111	*****	*****
Ladder Bracket	ZA116	ZB116	ZC116	ZC116	ZC116
Wood Rod Guide 3 Post	ZA119	ZA119	ZA119	ZA119	ZA119
Ladder Bracket Stay	*****	*****	ZC120	ZC120	ZC120
Ladder Stay	*****	*****	ZC121	ZC121	ZC121
Helmet	ZA124b	ZB124b	ZC124b	ZD124b	ZD124b
Oil Ring Guide	ZA127b	ZB127b	ZC127b	ZD127b	ZD127b
Vane Rib Assembly	ZA131b	ZB131b	ZC131b	ZD131b	ZD131b
Vane Triangle	ZA132	ZB132	ZC132	ZD132	ZE132
Rotating Ladder	*****	*****	ZC133	ZC133	ZC133
Wood Rod Guide 4 Post	ZA135	ZA135	ZC135	ZC135	ZC135
Vane Bracket Assembly	ZA137	ZB137	ZC137	ZD137	ZE137
Wheel Arm Clamp	ZA140b	ZB140b	ZC140b	ZD140b	*****
Inner Vane Sheet	ZA145c	ZB145c	ZC145c	ZD145c	ZE145c
Outer Vane Sheet	ZA146c	ZB146c	ZC146c	ZD146c	ZE146c
Stub Tower 4 Post	ZA147	ZB147	ZC147	ZD147	ZE147
Reefing Rocker Bracket 4 P	ZA148	ZA148	ZC148	ZC148	ZC148
Stub Tower Girt 4 Post	ZA149	ZA149	ZC149	ZC149	ZC149
Guard for Guide Bar	ZA161	ZA161	ZA161	ZD161	ZD161
Reefing Rocker 4 Post	ZA166	ZB166	ZC166	ZD166	ZE166
Link for Reefing Collar 4 P	ZA167	ZB167	ZC167	ZD167	ZE167