

**Instruction Manual for**

# **SOUTHERN CROSS**

## **'IZ' PATTERN WINDMILLS**

<b>6ft.</b>	<b>"IZ-A"</b>
<b>8ft.</b>	<b>"IZ-B"</b>
<b>10ft.</b>	<b>"IZ-C"</b>
<b>12ft.</b>	<b>"IZ-D"</b>
<b>14ft.</b>	<b>"IZ-E"</b>

---

**Manufactured in Australia by TOOWOOMBA FOUNDRY PTY. LTD.  
and Marketed by SOUTHERN CROSS MACHINERY COMPANIES.**

**ERECTION AND MAINTENANCE INSTRUCTIONS**  
**FOR**  
**SOUTHERN CROSS**  
**"IZ" Pattern Windmills**

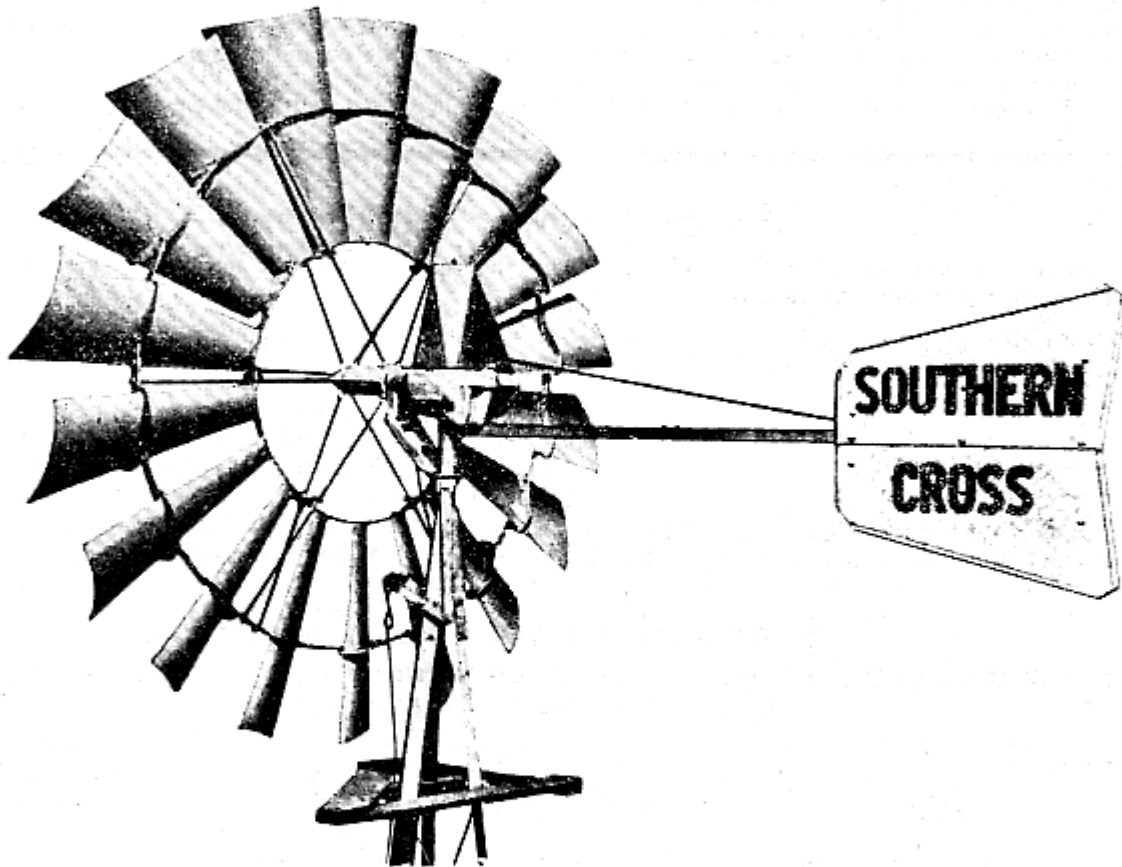

SOUTHERN CROSS "IZ" Pattern Windmills are made in five different sizes:—  
6ft., 8ft., 10ft., 12ft., and 14ft. diameter of Windwheel.

The outstanding features of these Mills are:—

- ★ Replaceable Bearings in Gearbox.
- ★ Completely enclosed, dust and weather proof.
- ★ Strong Tension Arm Windwheel with Galvanised Steel Fans.
- ★ Automatic Oiling.
- ★ Double Reduced Gears with Machine Cut Teeth.
- ★ All Steel Parts Heavily Galvanised.

The Southern Cross Windmill and Tower must stand plumb. If it does not, it will not regulate well and cannot face the wind properly.

The Tower must be central over the bore or pump pipe. If it is not, the pump rods will rub on the side of the pipe and the Mill will not work in light winds.

The plunger must not strike the top or bottom of the pump cylinder. If it does, it will cause breakages. The Tower Legs, Girts, and Braces must be straight and all Girts and Braces must be in place.

If a Girt or Brace is omitted for a single day you are liable to lose your windmill. They are absolutely essential to the strength of the Tower.

It is most important that your Tower be high enough so that your mill will be at least 20ft. above the highest surrounding objects. This will ensure a good wind exposure for the mill. When partly sheltered by high surrounding objects the mill will not run in light winds, and the irregular gusts around the obstructions will endanger the outfit.

**DOUBLE-ACTING PUMPS INVALIDATE WARRANTY**

This Windmill is suitable for use with single-acting plunger pumps in which the water is discharged on the "up" stroke. However, it is not suitable for use with double-acting pumps which discharge water on both the "up" and "down" strokes.

The Warranty on this Windmill will be null and void if it is used with a double-acting pump.

**Mill and Tower Packages**

Before commencing to erect the mill, make sure that all the mill and tower packages are at the site. Check to see that you have the following packages:

- MILL ..... Two boxes and two bundles
- TOWER ..... Four bundles for a 20ft. tower
- Five bundles for a 25ft. tower
- Five bundles for a 30ft. tower
- Six bundles for a 40ft. tower
- Seven bundles for a 50ft. tower
- Eight bundles for a 60ft. tower

The bolts for the mill are packed in a bag in Box No. 2, and the bolts for the tower are packed in bags which are included in the bundles. All tower bundles, except Nos. 1, 2, and 4, have bags of bolts with them.

**Foundations for the Tower**

**THIS TOWER MUST BE SET IN FIRM CONCRETE FOUNDATIONS AND UNDER NO CIRCUMSTANCES IS IT TO BE ATTACHED TO WOOD BLOCKS.**

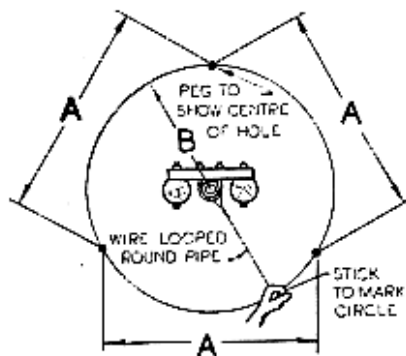

HEIGHT OF TOWER	A	B
20 FT.	4'-11"	2'-10"
25 FT.	6'-0"	3'-5 1/2"
30 FT.	7'-1"	4'-1"
40 FT.	9'-3"	5'-4 1/8"
50 FT.	11'-5"	6'-7 1/8"
60 FT.	13'-7"	7'-10 1/8"

Marking the Foundation Holes

It is essential that the Windmill Tower should be set plumb and centrally over the Bore and Pump Pipe so the position for the foundation holes must be located exactly. Proceed as follows:—

- (1) Make a loop of wire which will encircle the end of the bore casing or pump pipe. (See illustration.)
- (2) Refer to table under illustration, "Marking the Foundation Holes", and determine the correct radius "B" for the height of the tower to be erected.
- (3) Fix a stick to the wire at the correct radius "B", and draw a circle.
- (4) From the table determine "A" for the height of tower and mark off this distance around the circle. The three points obtained are the centres of the foundation holes.
- (5) Dig the foundation holes, sloping them outwards 1 1/2 in. per foot of depth. For the 6ft. and 8ft. Towers sink the holes 3ft. 2in. deep and 3ft. 10in. deep for the 10ft., 12ft., and 14ft. Towers. If the Tower is being erected on a hillside, sink the shallowest hole to the depth mentioned. Dig out the bottom of the three foundation holes to provide a "foot". (See illustration, "Digging the Foundation Holes", on Page 3.)
- (6) Drive a stake into the bottom of one hole so that it projects about 6in. from the bottom. Take another stake and do the same in one of the other holes.

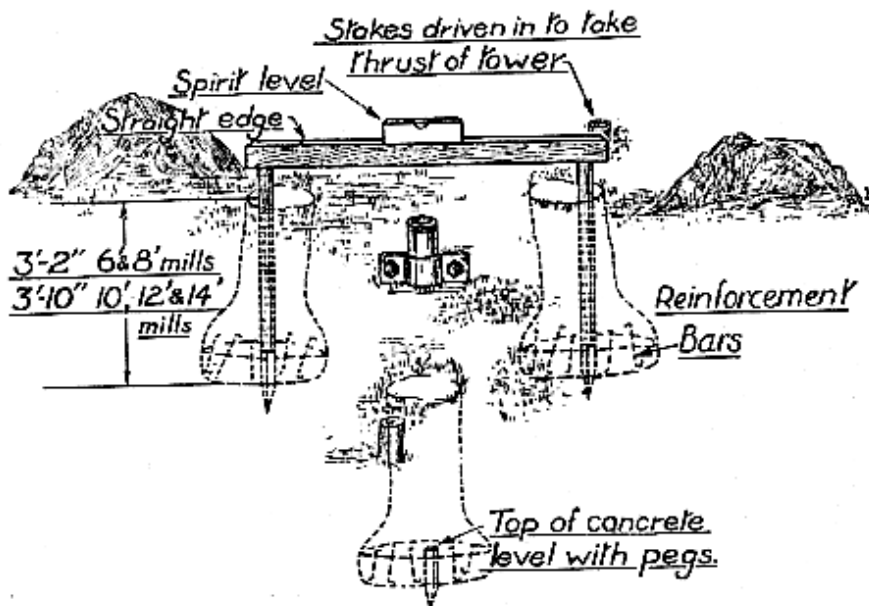

Digging of Foundation Holes

three holes until it is level with the tops of the stakes, i.e., about 6in. deep.

- (11) Place Reinforcements, such as old bars or bolts, in this concrete so that they project about 6in. from the concrete. (See illustration, "Concreting the Tower Anchor Posts", on Page 9.)

- (7) Cut two pieces of timber exactly the same length and about four feet long. Stand these pieces on top of the stakes in the two holes and across the top, lay a straight piece of timber of even thickness.
- (8) With a spirit level on the straight piece of timber, check for level. If it is not level, drive down the high stake until it is.
- (9) Drive a stake into the third hole and check for height, using the above method until the tops of the three stakes are level.
- (10) Mix a batch of concrete using three parts of sand, six parts of stone or rubble and one of cement. Ram concrete into the bottom of the

## To Assemble Tower

**IMPORTANT.**—See that each bolt is used in its correct place (refer illustration, "Assembling the Tower" on Page 4). The heads of all bolts are to be inside the tower and the nuts outside.

- (1) Undo the bundles containing the 10ft. Leg Sections. On 25ft. Towers only, three 5ft. leg sections will be found in one of the bundles. These 5ft. leg sections are to be used only at the bottom of the tower.  
NOTE: On 6ft. and 8ft. Mills, the three 10ft. leg sections packed in the No. 1 Bundle must be bolted to the stub tower, so do not mix them with other 10ft. leg sections.

No. 1 Bundle is the one in which the short steel angle girts for the top of the tower are packed.

- (2) Proceed to assemble one side of the tower complete before putting on the other two sides.
- (3) Take two 10ft. leg sections and bolt the top ends (i.e. the end with the corner cut away) to the inside of the Stub Tower with the bolts shown in the illustration, "Assembling the Tower," on page 4. Leave the nuts loose on the bolts. Spring Washers are to be used on these bolts.
- (4) Complete these two legs by bolting on the lower leg sections in each case, making sure that the top end (i.e., the end with the corner cut away) is bolted inside the bottom of the other leg. On a 25ft. Tower the 5ft. section will be the last one bolted on each leg. The short bolts at each leg joint (i.e., the top bolts or ones nearest the Stub Tower) can be tightened up, but the nuts on the long bolts are left loose.
- (5) Lift the Stub Tower end of the tower and rest it on a box or block of wood.
- (6) Take one of each of the different length girts and bolt them in position OUTSIDE the legs with the projecting flange of the angle nearest the Stub Tower. Leave the nuts loose.
- (7) Lay the bundles of braces in order of their number, beside the tower as follows:

No. 1 Bundle	.....	Single Braces between 1st and 2nd Girts
No. 2 Bundle	.....	Double Braces between 2nd and 10ft. Girts
No. 3 Bundle	.....	Double Braces between 10ft. and 15ft. Girts
No. 4 Bundle	.....	Double Braces between 15ft. and 20ft. Girts
No. 5 Bundle	.....	Double Braces between 20ft. and 25ft. Girts
No. 6 Bundle	.....	Double Braces between 25ft. and 30ft. Girts
No. 7 Bundle	.....	Double Braces between 30ft. and 35ft. Girts
No. 8 Bundle	.....	Double Braces between 35ft. and 40ft. Girts
No. 9 Bundle	.....	Double Braces between 40ft. and 45ft. Girts
No. 10 Bundle	.....	Double Braces between 45ft. and 50ft. Girts
No. 11 Bundle	.....	Double Braces between 50ft. and 55ft. Girts
No. 12 Bundle	.....	Double Braces between 55ft. and 60ft. Girts
No. 13 Bundle	.....	Double Braces below 60ft. Girts.

All the above braces are used on a standard 60ft. tower. On lower towers, lay the bundle of braces out as set out, and it will be found, if your laying out is correct that there is one bundle of three double braces which comes in the section between the last girt and the end of the tower.

Be very careful not to mix the braces when the bundles are opened, as it is difficult to find the correct braces for each section if they are mixed.

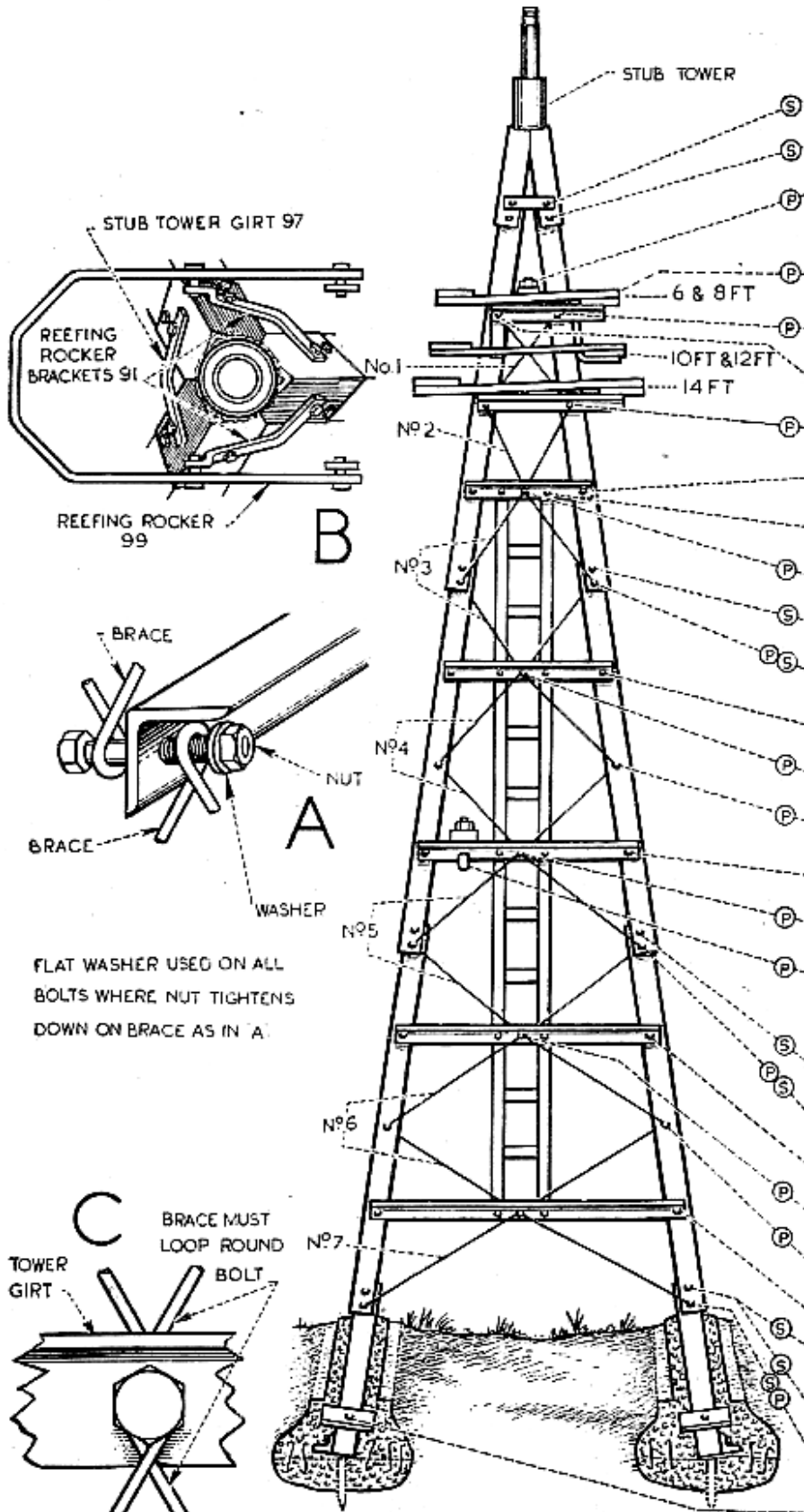

— SIZES OF BOLTS —			
NAME OF PART	6 & 8 FT.	10 FT.	12 & 14 FT.
REEFING ROCKER BRACKET	1 x 3/8	1 1/4 x 3/8	1 1/4 x 1/2
STUB TOWER	1 x 3/8	1 x 3/8	1 1/4 x 1/2
GUIDE FOR PUMP ROD	3/2 x 3/8	4 x 3/8	HOOK
PLATFORM TO GIRTS OR PLATFORM BRACKET	1 3/4 x 5/16	1 3/4 x 5/16	1 3/4 x 5/16
PLATFORM TOGETHER	M6x 65mm CARRIAGE		
1ST. GIRTS	1 x 3/8	1 x 3/8	1 x 3/8
1ST. GIRTS & PLATFORM BRACKET - 10 & 12 FT.		1 1/4 x 3/8	1 1/4 x 3/8
SECOND GIRTS	1 1/4 x 3/8	1 1/4 x 3/8	1 1/4 x 3/8
10 FT. GIRTS	3/4 x 3/8	3/4 x 3/8	3/4 x 3/8
LADDER TO GIRTS	3/4 x 5/16	3/4 x 5/16	3/4 x 5/16
BRACE TO GIRTS	1 3/4 x 3/8	1 3/4 x 3/8	1 3/4 x 3/8
LEG JOINT	3/4 x 3/8	1 x 3/8	1 x 1/2
LEG & WIRE BRACE 1 1/4 x 3/8		1 1/2 x 3/8	1 3/4 x 1/2
15 FT. GIRTS	3/4 x 3/8	3/4 x 3/8	3/4 x 3/8
BRACE TO GIRTS	1 1/2 x 3/8	1 1/2 x 3/8	1 3/4 x 3/8
BRACE TO LEG	1 x 3/8	1 x 3/8	1 1/4 x 1/2
20 FT. GIRTS	3/4 x 3/8	3/4 x 3/8	3/4 x 3/8
BRACE TO GIRTS	1 3/4 x 3/8	1 1/2 x 3/8	1 3/4 x 3/8
PIPE STAY	3 1/2 x 3/8	3 1/2 x 3/8	4 x 3/8
	HOOK	HOOK	HOOK
LEG JOINT	3/4 x 3/8	1 x 3/8	1 x 1/2
LEG & WIRE BRACE 1 1/4 x 3/8		1 1/2 x 3/8	1 3/4 x 1/2
25 FT. GIRTS	3/4 x 3/8	3/4 x 3/8	3/4 x 3/8
BRACE TO GIRTS	1 1/2 x 3/8	1 3/4 x 3/8	1 3/4 x 3/8
BRACE TO LEG	1 x 3/8	1 x 3/8	1 1/4 x 1/2
30 FT. GIRTS	3/4 x 3/8	3/4 x 3/8	3/4 x 3/8
ANCHOR POST TO LEG (6 FT. ONLY)	3/4 x 3/8		
ANCHOR POST TO LEG	1 x 3/8	1 x 1/8	1 x 1/2
ANCHOR POST & WIRE BRACE TO LEG	1 1/4 x 3/8	1 1/4 x 3/8	1 1/2 x 1/2
FOUNDATION PLATE	1 x 1/2	1 x 1/2	1 x 1/2

---(P)--- FLAT WASHER FITTED UNDER NUT  
 ---(S)--- SPRING WASHER FITTED UNDER NUT  
**Assembling the Tower**

- (8) Take two Bundle No. 1 Braces and bolt them inside the two legs between the first and second girts, using the bolts which hold the girts to the leg. Leave the nuts loose on these and all other bolts when fitting the rest of the braces. Only screw them on about three threads.
- (9) Take one Bundle No. 2 Brace, bolt one end outside the leg with the bolt that holds the 2nd girt, loop the brace around the bolt at the middle of the 10ft girt (see "A" and "C" in illustration, "Assembling the Tower"), and bolt the other end outside the leg at the other end of the 2nd girt.
- (10) The rest of the braces for the various sections form what is known as "diamond" bracing. The brace, forming the half of the diamond nearest the stub tower, is fitted outside the legs and girt, and the other brace inside the legs and girt. BRACES MUST LOOP AROUND THE BOLT AT THE MIDDLE OF THE GIRT, OTHERWISE THEY WILL BE SLACK AND USELESS FOR THE STRENGTH OF THE TOWER. THE LOOPING ROUND THE BOLT SHORTENS THEM ENOUGH TO GIVE THEM THE NECESSARY TENSION.

- (11) Take two Bundle No. 3 Braces and fit them. The ends of the braces go to the long bolt in the leg joint. The brace which loops around the bolt at the middle of the 10ft. girt fits outside the girt and legs. The other brace fits inside the legs and 15ft. girt. The rest of the braces between girts are fitted in the same way, except that in alternate sections the ends are bolted to the leg by a separate bolt instead of a leg-joint bolt.

A FLAT WASHER IS TO BE USED ON ALL BOLTS WHERE THE NUT TIGHTENS DOWN ON THE BRACE. (See illustration "A", "Assembling the Tower".) At leg joints, a plain washer and a spring washer are fitted over the eye of the brace, on the outside of the tower leg. (See illustration, "Attaching Braces at Leg Joints".)

- (12) Fit all the braces between the girts, but do not fit those in the last bundle (i.e., the one between the last girt and the end of the tower). These braces are fitted later.
- (13) Now assemble the Ladder Section. Place the Side Rails on a block of wood, with the slotted flange downwards and drive in the rungs with a piece of wood. Drive the other side rail on in a similar manner. (See illustration, "Assembling the Ladder Sections".)
- (14) Now bolt the ladder in position. The top end is to be bolted to the 10ft. girt. (See illustration, "Assembling the Tower".) On 25ft. Towers keep the 5ft. section to the bottom.
- (15) One side of the Tower has now been completed.
- (16) Place packing cases or pieces of timber under the legs of the tower now assembled and make sure that there is no sag and the legs are straight.
- (17) Bolt on the 1st, 2nd, and 10ft. Girt for the two remaining sides so that they project upwards to take the third leg.

- (18) Take a 10ft. leg section and bolt it on inside the Girts just put on, thus forming the start of the third leg. On 6ft. and 8ft. Mills, use the remaining leg section from the No. 1 Bundle.
- (19) Bolt the Reefing Rocker Assembly to the top joint holes in the Stub Tower, as shown in the illustration, "Assembling the Tower" at "B". The Reefing Collar is slipped on position on the Pivot Tube when attaching the Reefing Rocker Assembly. Fit Spring Washers on the bolts. The Reefing Rocker must be fitted over the side of two Legs of the Tower and not on the corner or over one leg of the Tower. See "B" on illustration, "Assembling the Tower", on Page 4.

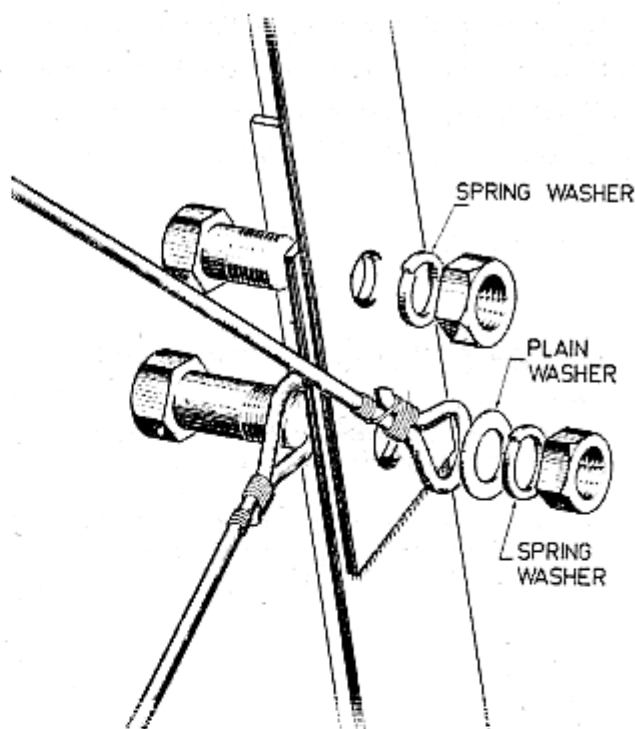

Attaching Braces at Leg Joints.

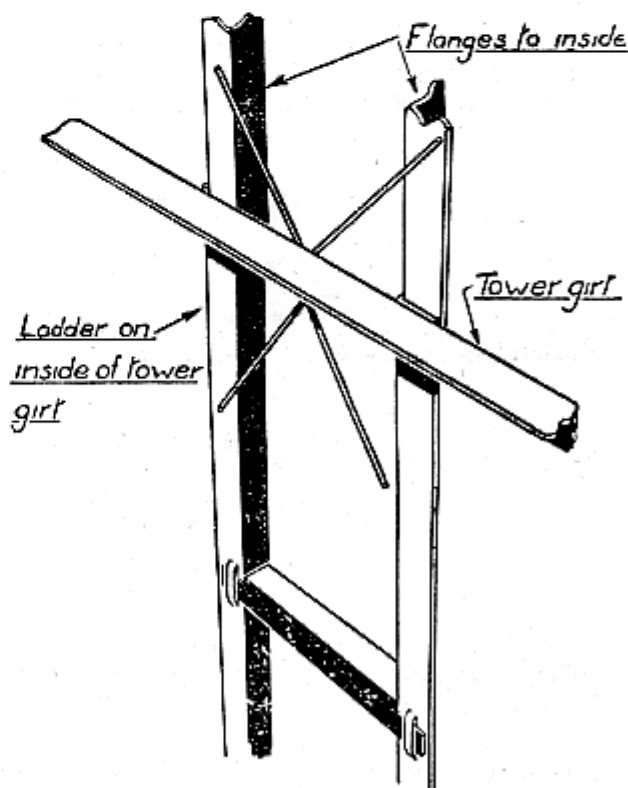

Assembling the Ladder Sections.

- (20) Bolt the Stub Tower Girt to the other two top joint holes in the Stub Tower, fitting **Spring Washers**.
- (21) Now fit the braces to complete the three sides of the top 10ft. section.
- (22) The rest of the tower can now be built, bolting on the Girts first, then the leg section, and finally the braces. Bolt the nameplate, supplied, between a girt and a tower leg near the bottom of the tower.

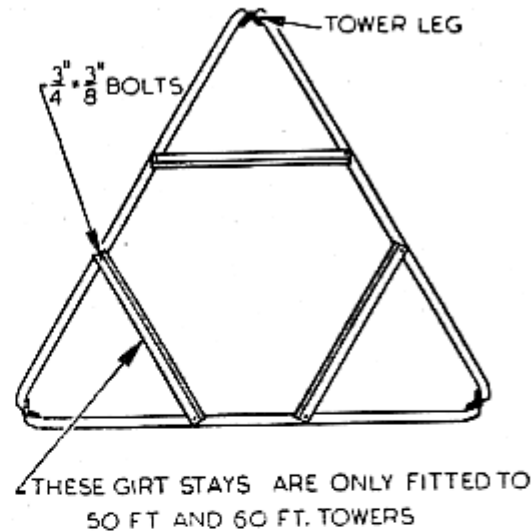

- (23) 50 FOOT AND 60 FOOT TOWERS ONLY:

On 50 Foot Towers fit the girt stays to the two sets of girts nearest the bottom of the tower.

On 60 Foot Towers fit the girt stays to the four sets of girts nearest the bottom of the tower.

- (24) Now tighten up the bolts on the Tower, starting at the top. Leave the bolts at the middle of the girts until last and then tighten them gradually so that the braces are strained evenly and tightly. This does not necessarily mean that the nuts on the bolts in the middle of the girts will be tightened right up.

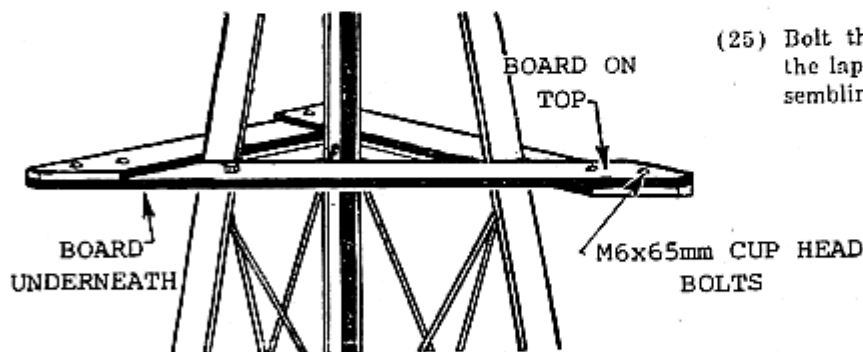

*Assembling the Platform*

- (25) Bolt the three Platform boards together so the laps are as shown in the illustration, "Assembling the Platform."

- (26) Now fit the Platform on to the Tower. On 6ft. and 8ft. mills the platform is bolted to the 1st Girt which extends on the right when looking at the side of the tower. On 10ft. and 12ft. mills the platform is bolted to

platform brackets, which are bolted to the left hand ends of the first girts. On 14ft. mills the Platform is bolted to the 2nd Girt, which extends on the right. When looking at the edge of the Platform, the boards should be under on the left hand side and on top on the right hand side.

- (27) Using the long bolts supplied, bolt a heavy piece of timber across the bottom of the two lower legs so that the timber projects about two feet out on each side.

- (28) The tower is now ready to erect.

**IMPORTANT:** Do not fit the Mill Engine before erecting the tower. Instructions shown in No. 12 on Page 9 show why this is necessary.

## To Erect Tower

- (1) Drive in two stakes in line with two of the foundation holes about 1ft. 6in. outside of them. These stakes will take the thrust of the tower as it is being pulled up.
- (2) For 6ft. and 8ft. Towers up to 40ft. and 10ft., 12ft. and 14ft. Towers up to 30ft., push the Tower up, using a pipe as a stay until it is high enough to pull up with the block and tackle on the other side. Refer to the illustration, "Erecting the Tower," (below), which shows the method of pushing the tower up part of the way and pulling it the rest of the way by means of a double and single block and tackle.

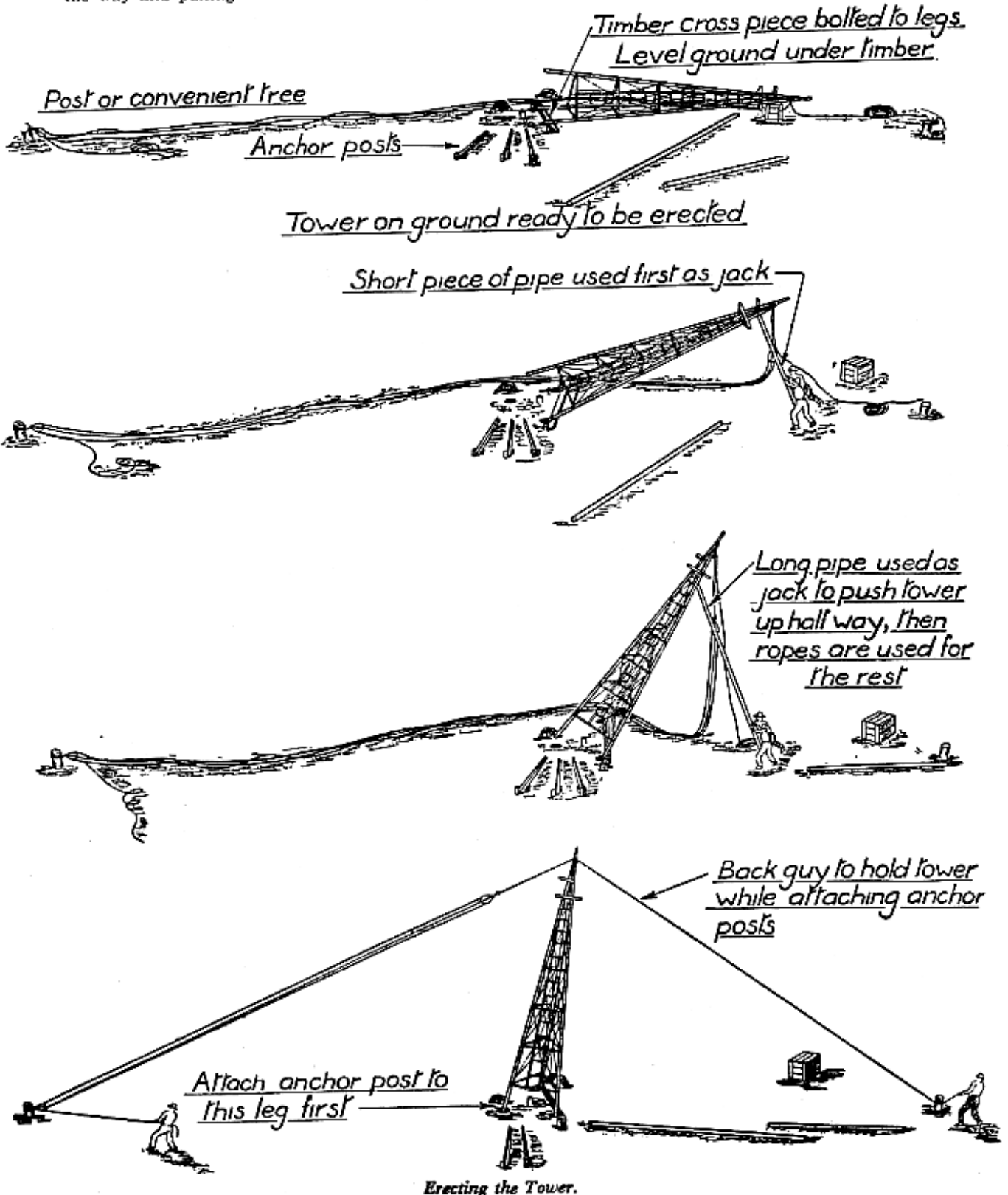

Erecting the Tower.



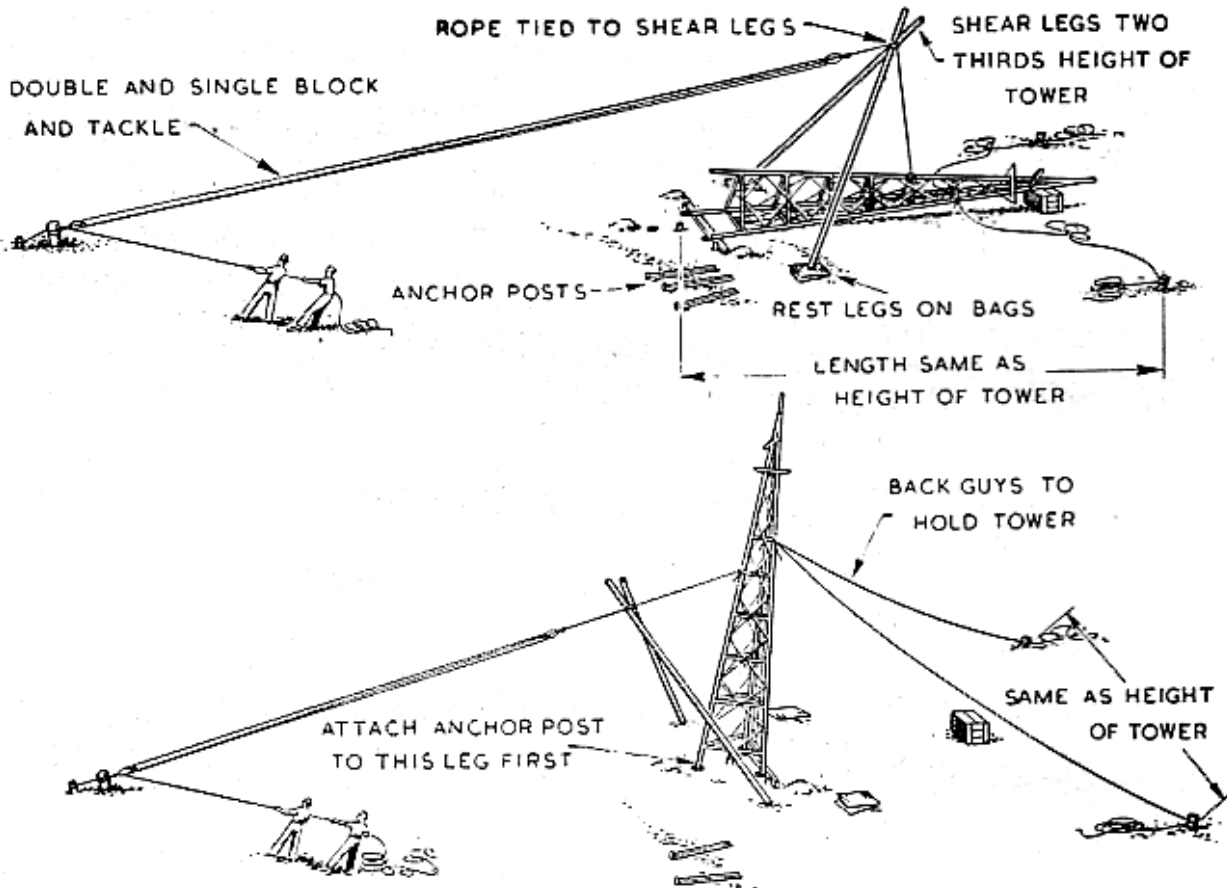

Erecting the Tower.

- (3) For towers higher than those mentioned in (2), make a pair of shear legs in the manner shown in the illustration, "Erecting the Tower" (above). The timber or pipe used should be approximately two-thirds the height of the tower.
- (4) When rigging the tackle for these higher towers, use double and treble blocks if they are available. The treble block is secured to a convenient tree or a post sunk well into the ground.
- (5) Tie the lifting rope to the top leg at a point half way up the tower, where girts are bolted to the leg. Also tie the lifting rope to the fork of the shear legs leaving sufficient slack to allow the lift to be taken as shown in the illustration.
- (6) **50 FOOT AND 60 FOOT TOWERS.** Before erecting 50 and 60 foot towers, the bottom leg sections must be reinforced as shown in the illustration, "Reinforcing Legs for Erection" (below). Use wooden pipe stays, pump rod guides or similar timber at least 6 feet long. Place the end of the timber support about 18 inches down the leg past the bottom girt, and then wire the support on tightly at the points shown. The longest supports should be used on the legs nearest the ground and for preference, should be nine to ten feet long. The supports are removed after the tower is pulled up.
- (7) Pull up the Tower.
- (8) Fit the Foundation Plates to the lower end of the Anchor Posts and attach one Anchor Post to the leg without the timber crosspiece. When putting in the bottom bolts, bolt the remaining bottom braces in position, but do not bolt the loop at the middle to the bottom girt. This is done after the tower legs have been concreted.

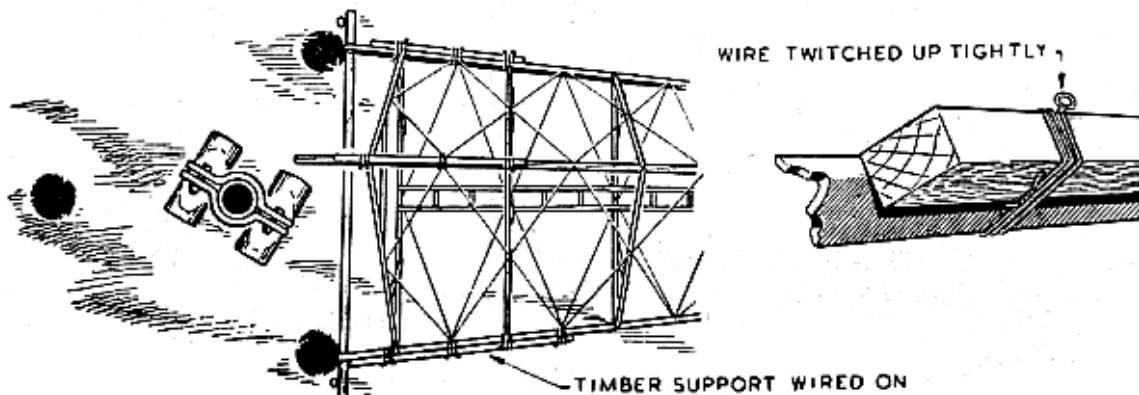

Reinforcing Legs for Erection—50 and 60 Foot Towers.

- (9) Undo one of the guy ropes and take it around until it can be used to take the weight off one of the other legs. Undo the end of the timber crosspiece at this leg and fit the Anchor Post.
- (10) The other Anchor Post is attached in a similar manner.
- (11) Check the tower for centre over the bore using a measuring stick between the legs and the bore, or a plumb-bob and line hung down from the centre of the Pivot Tube. If necessary shift the tower until it is central.
- (12) After the Tower is central, check it for plumb by means of a spirit level in three positions round the Pivot Tube. The Pivot Tube is the extreme top part of the Stub Tower. It is very important that this is carefully checked.

If it is not plumb, pack under the legs to correct the error and then check the tower again for centre.

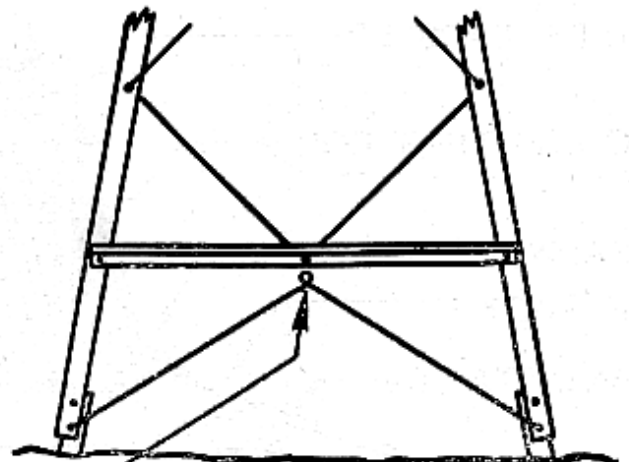

THIS LOOP NOT TO BE BOLTED TO BOTTOM GIRT UNTIL TOWER LEGS ARE CONCRETED.

Fitting Bottom Brace

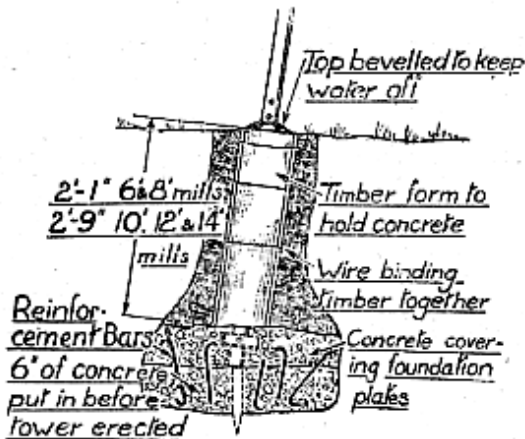

Concreting the Tower Anchor Posts.

- (13) Clean up the surface of the concrete already laid in the bottoms of the holes. Any dirt on the surface will prevent the two batches of concrete from binding.
- (14) Mix up another batch of concrete, using three parts sand, six parts of stone and one part of cement, and ram about 7 inches of concrete in the bottom of each hole.
- (15) Then make three wooden forms to go down around the legs. See illustration, "Concreting the Tower Posts." They are made in the form of a triangle, and are 2ft. lin. long for 6ft. and 8ft. Mills, and 2ft. 9in. long for 10ft., 12ft. and 14ft. Mills. Nail two wide boards together to form a right-angle. The other board is wired in position when the form is put around the leg.
- (16) Fill the forms with concrete and shape the top so that it will shed water.
- (17) Allow concrete to set for a day, then remove the forms and ram earth in around the concrete.

## To Assemble the Mill Engine

(See illustration, "The Mill Engine," on Page 10).

- (1) Remove the Mill Engine from its crate.
- (2) Put the Crosshead Roller into position in the Guide Bars, No. 58, and remove the fixing pins from the Guide Bars. Then fit the Guide Bars into the Gearbox bosses. Drive the fixing pins into the Gearbox bosses from the wheel side, and slightly rivet the end not headed, using a dolly and punch. The pin on the gear-wheel side can be inserted through one of the holes in the web of the gearwheel.
- (3) Check to see that the two crosshead oil rings are round and free in the guides. If the rings have been bent during transit they can be trued up by hand.
- (4) Clean and oil the hole for the Pivot Tube on the underneath side of the gearbox.
- (5) Put some grease in the Vane Hinge Bearing in the back of the gearbox.

## To Fit the Mill Engine on Stub Tower.

- (1) Thoroughly clean the Pivot Tube.
- (2) When the Pivot Tube is quite bright and polished, smear oil over it. Never leave the Pivot Tube unprotected for any period, because any rust at all on it will prevent the Turntable from functioning as freely as it should.
- (3) Three Anti-Friction Washers, No. 66, are fitted in the Turntable Collar at the Factory. Check that they are in place and pour a small amount of oil on them.
- (4) Make sure that the Reefing Rocker, No. 99, Links, No. 100, and Reefing Collar, No. 20, work freely on the Mast Pipe.

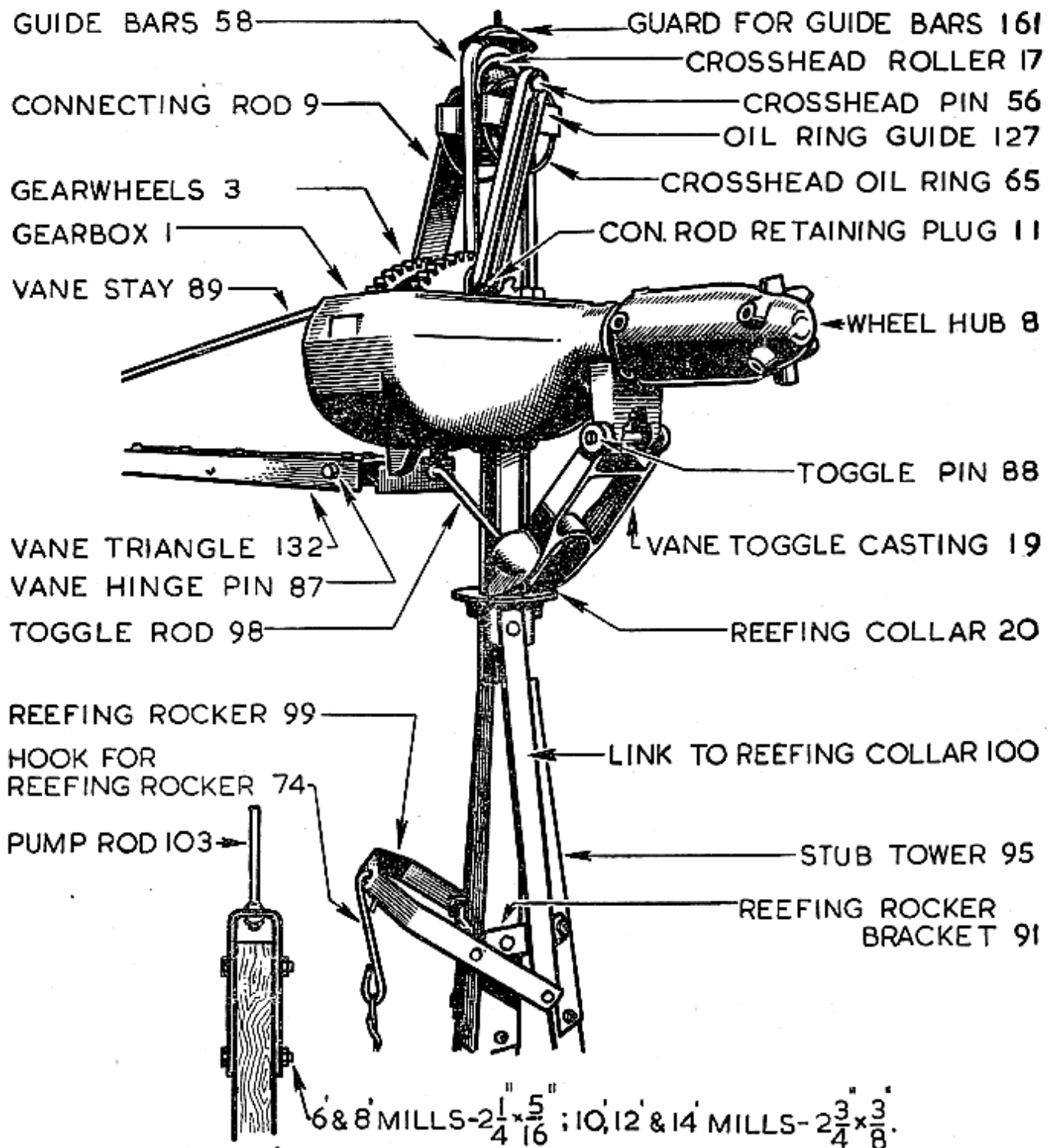

The Mill Engine.

(5) 6ft. Mills.—Carry the Mill Engine up the Tower or place a rope around it and pull it up and place it in position on the Pivot Tube. Now take the Turntable Pivot Tube Circlip, No. 25, and drive it into position in the groove near the top of the Pivot Tube. It is driven on from the side and not down over the top end. This circlip prevents the Mill engine from lifting off the Turntable. This completes the fitting of the mill engine on the stub tower for 6ft. Mills, and you can now proceed to fit the vane.

- (6) 8ft., 10ft., 12ft. and 14ft. Mills.—(Refer to illustration at right.) Erect a pole as in the illustration, using a length of pipe from the Pump Piping, and a couple of pieces of timber such as Pipe Stays. The piece of timber which holds the pole to the Stub Tower is held with "U" Bolts—one supplied with the Mill and the other with the Pipe and Rods. **NOTE:** The top piece of timber must be bolted to the Stub Tower below the Reefing Collar. Drill the piece of timber as shown in the illustration; i.e., centres for "U" Bolts to be 11in. apart.
- (7) Obtain another piece of timber and drill it to suit another pipe "U" bolt.
- (8) Using a "U" Bolt, clamp the top piece of timber to the Stub Tower so that the pole, when attached, will be over one of the Tower Legs.
- (9) Using double and single blocks, prepare your blocks and tackle and carry it up to the Tower Platform. If available, use treble and double blocks for 12ft. and 14ft. mills.
- (10) Pull the pole up the Tower.
- (11) Hook the double block to the top of the pole and then push it up until the top is about 6ft. above the top of the Stub Tower.
- (12) Clamp the pole to the piece of timber which is already attached to the Stub Tower. See illustration, "To Fit Mill Engine on Stub Tower".
- (13) The other piece of timber is then clamped to the pipe so that it rests on the Platform and takes the weight. Wire it to the Platform to keep it from slipping.
- (14) Attach the rope to the Gearbox and pull it up and place it in position on the Pivot Tube.
- (15) Now take the Turntable Pivot Tube Circlip, No. 25, and drive it into position in the groove near the top of the Pivot Tube. It is driven on from the side and not down over the top. This Circlip prevents the Mill Engine from lifting off the turntable.
- (16) Do not remove the pole yet, as it is used to pull up the Vane.

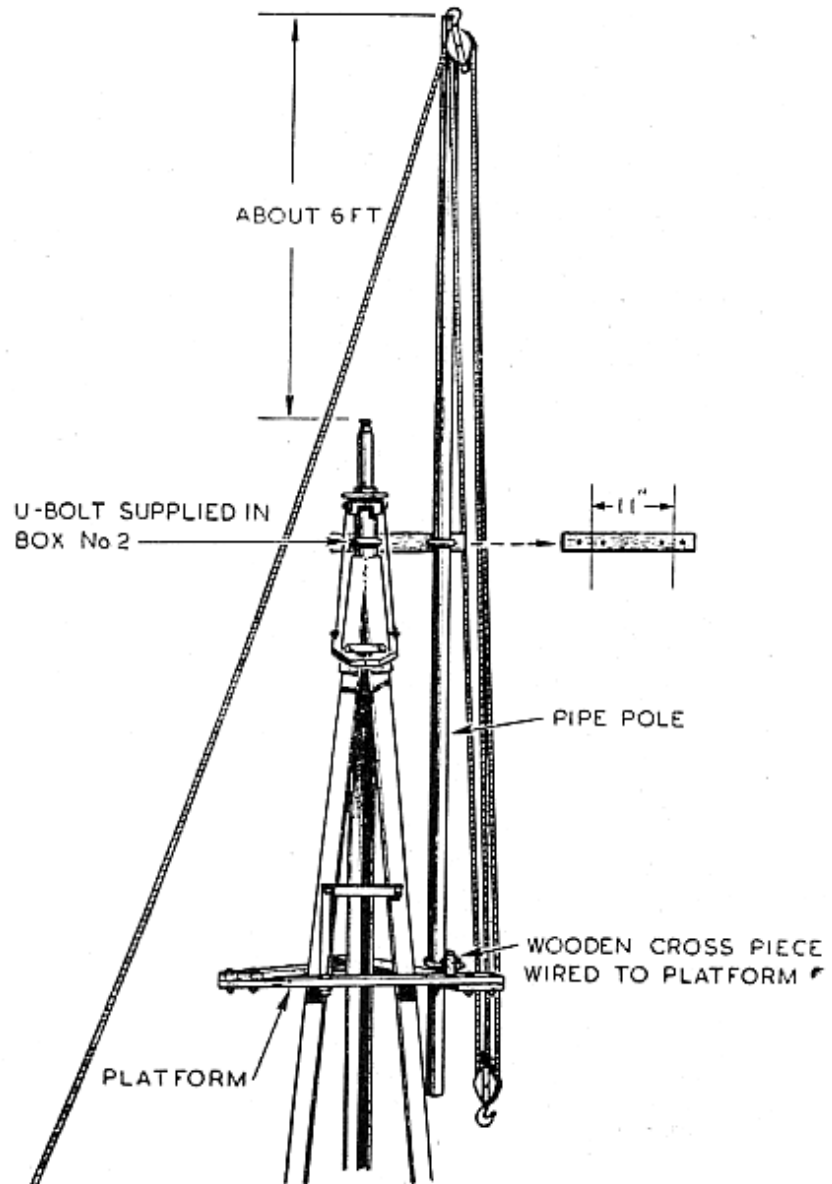

To Fit Mill Engine on Stub Tower.

### To Fit the Vane

- (1) Assemble the Vane on the ground. Lie the two Vane Sheets flat on the ground with the small end of the fish tail to the right. (See illustration, "Assembling the Vane".) Lap the sheets so the holes line up at the joint. Lie the Vane Ribs on top of the sheets and bolt them on, using 3/4in. x 9/32in. Cup Head Bolts at the ends of the ribs. Put the Vane Triangle in position and bolt the Vane Sheets and Ribs to the Triangle. Fit flat washers between the bolt heads and the Vane Sheets.
- (2) Hook the Vane Stay in place in the Vane Triangle and temporarily wire it to the Triangle near the mill engine end.

For Windmills which have Threaded Section on Vane Stay: Hook threaded section of Vane Stay through Vane Triangle. Slip on the Vane Stay Spacer and tighten up the slotted nut. Insert cotter pin and spread. Temporarily wire Vane Stay to Vane Triangle near the mill engine end.

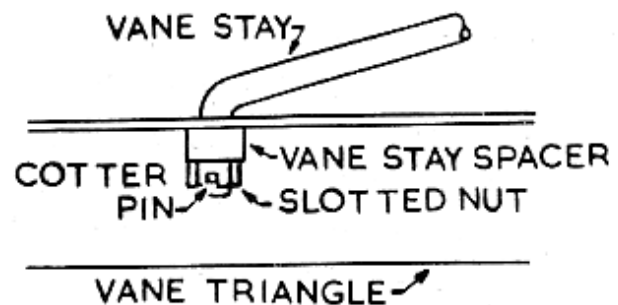

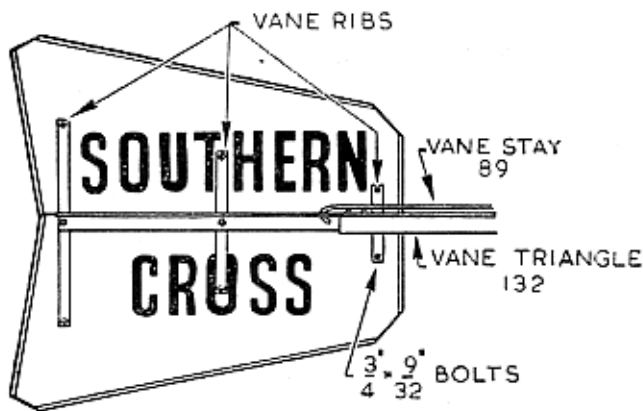

Assembling the Vane.

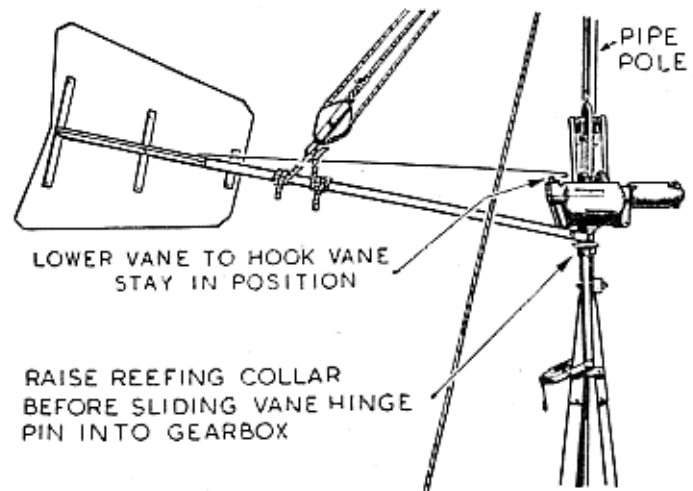

Assembling the Vane to the Mill Engine.

- (3) Grease the Vane Hinge Pin No. 87 and then take it, together with the Vane Hinge Pin Washer No. 84, and 2 bolts (6ft., 1½in. x ½in.; 8ft., 1½in. x 5/16in.; 10ft., 1½in. x ¾in.; 12ft. and 14ft., 2in. x ¾in.), up to the top of the Tower before pulling up the Vane. Then pull up the vane.
- (4) The section of the Vane Hinge Pin with two drilled holes in it fits into the Vane Triangle. Put it in the Triangle so the other section of the Hinge Pin is on the same side of the Triangle as the Vane Ribs and Vane Sheets.
- (5) Push the Reeving Rocker down and raise the Reeving Collar to the top of the Pivot Tube before fitting the Vane.
- (6) Then lift the Vane as shown in the illustration, "Assembling the Vane to the Mill Engine," and slide the Hinge Pin into position in the Gearbox. On 12ft. and 14ft. Mills, before lifting vane, shift top of pipe pole outwards so that when fitting the Vane the lift will be as near perpendicular as possible. On 6ft. Mills, a rope tied from the point of balance on the Vane to the top of the Guide Bars will take the weight while the Hinge Pin is inserted.
- (7) Fit the Vane Hinge Pin Washer to the top of the Hinge Pin, untie the Vane Stay and then hook the Vane Stay into the Hinge Pin by lowering the Vane slightly.
- (8) Immediately bolt the Vane Triangle to the Vane Hinge Pin, using two bolts specified in (3). Fit spring washers under the nuts.
- (9) Fit the Vane Toggle Casting, No. 19, to the Gearbox, grease the Toggle Pin No. 88, insert it and secure it with two split pins.
- (10) Grease the banjo shaped end of the Toggle Rod No. 98, put it into position in the Vane Toggle Casting, and then twist it and fit the other end through the hole in the end of the Vane Triangle. Fit a split pin to hold it in position.
- (11) On 8ft., 10ft., 12ft., and 14ft. Mills the pole can now be removed.
- (12) The Reeving Handle and Reeving Wire can now be fitted. The Reeving Handle is clipped on the inside of the leg nearest the Reeving Rocker, No. 99 (See illustration "Assembling the Reeving Handle"). The hook on the Reeving Rocker is connected to the hook in the Reeving Handle using the wire supplied. The wire is passed between the Platform and Tower.  
For 12ft. and 14ft. Mills a slightly different Handle and Clip are supplied, but they are attached to the Tower Leg and connected in a similar manner.
- (13) Reef the mill and adjust the position of the Reeving Handle Clip so that the Vane Triangle just comes round to the stop on the bottom of the gearbox.

It is very Important that the Reefing of the Mill is adjusted so that it does Not jam the vane triangle hard against its stop. This is done by raising or lowering the Clip on the Tower Leg. If the Vane Triangle is jammed hard up, the Mill will not pivot freely when Reefed.

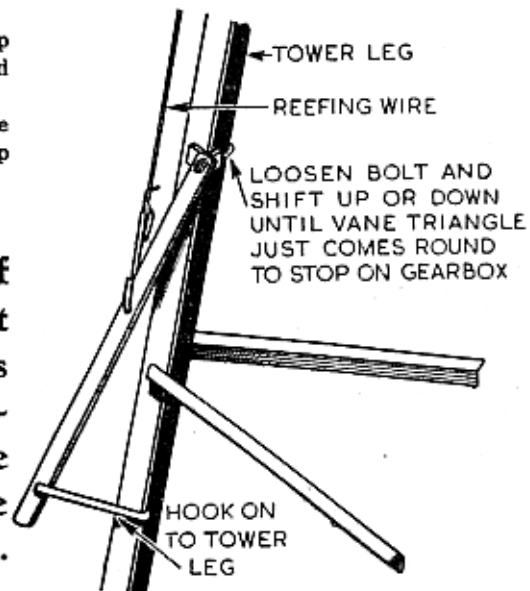

Assembling the Reeving Handle.

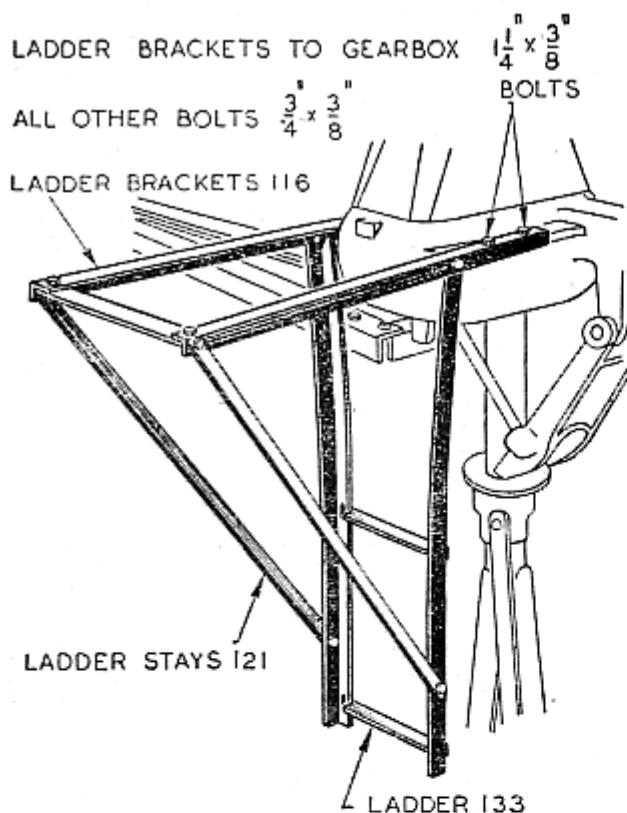

Assembling the Rotating Ladder.

### To Fit Rotating Ladder

(10ft., 12ft. and 14ft. Mills Only).

- (1) Assemble the Ladder, No. 133 and the Ladder Brackets, No. 116, and Stays, No. 121, on the ground. Fit Spring Washers under all nuts.
- (2) Pull up the assembled Rotating Ladder and attach it to Gearbox by means of four bolts. The top will have to be sprung out to fit it on the seating provided. See illustration, "Assembling the Rotating Ladder."

### To Fit Wheel

TO MAKE SURE THAT THE WHEEL IS FITTED CORRECTLY THE FOLLOWING INSTRUCTIONS MUST BE FOLLOWED VERY CAREFULLY, STEP BY STEP.

- (1) Assemble the Fans and Rings in sections. Put the Outer Fan Bracket on the Fans, making sure that the lip of the Bracket goes through the slot in the Fan so that it will hook over the inside of the Fan when the Ring is in place. As the Brackets are put on, stand all Fans on end where they will be easy to reach. See illustration, "Assembling Outer Fan Brackets on Fan."

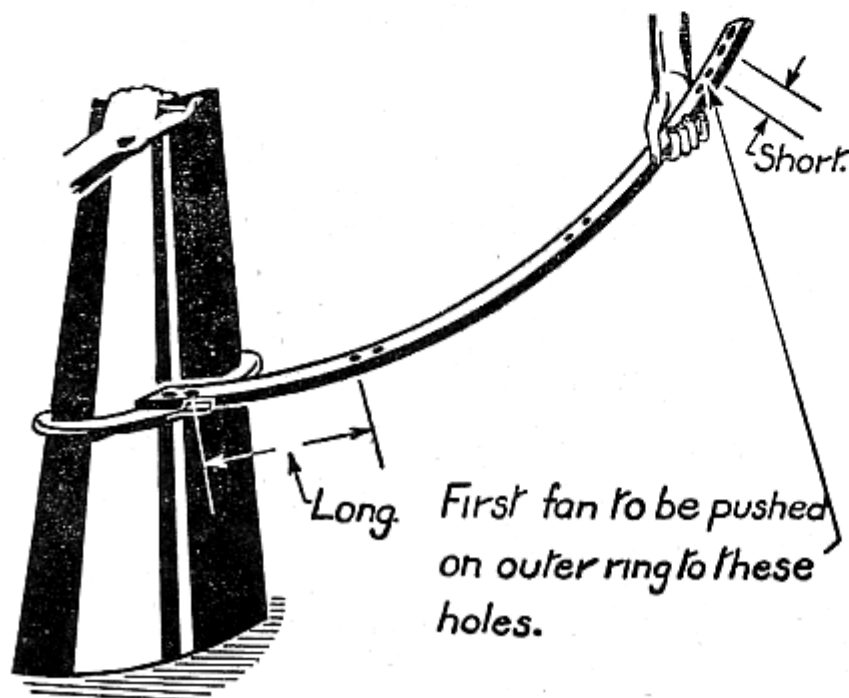

Assembling Fan on to Outer Ring Sections.

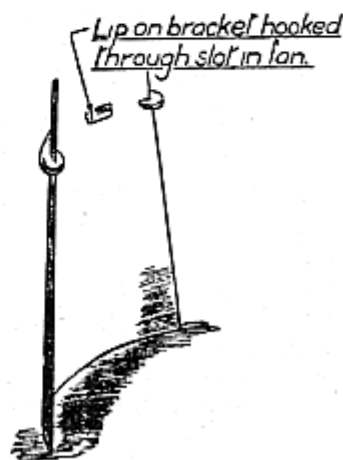

Assembling Outer Fan Brackets on Fan.

(2) Take an Outer Ring Section in your right hand, holding it by the end which has the Fan bolt holes nearest the end.

(3) Take a Fan in your left hand with the back side (the side with the bracket) towards you. Let the lower end of the Fan rest on the ground while you hold the upper end with the Fan slanting away from you just a little.

(4) Push the long end of the Ring through the slot in the Fan, as shown in illustration, "Assembling Fans on to Outer Ring Sections." Push it right through until the bolt holes in the Bracket line up with the second pair of holes from the end of the ring which you are holding.

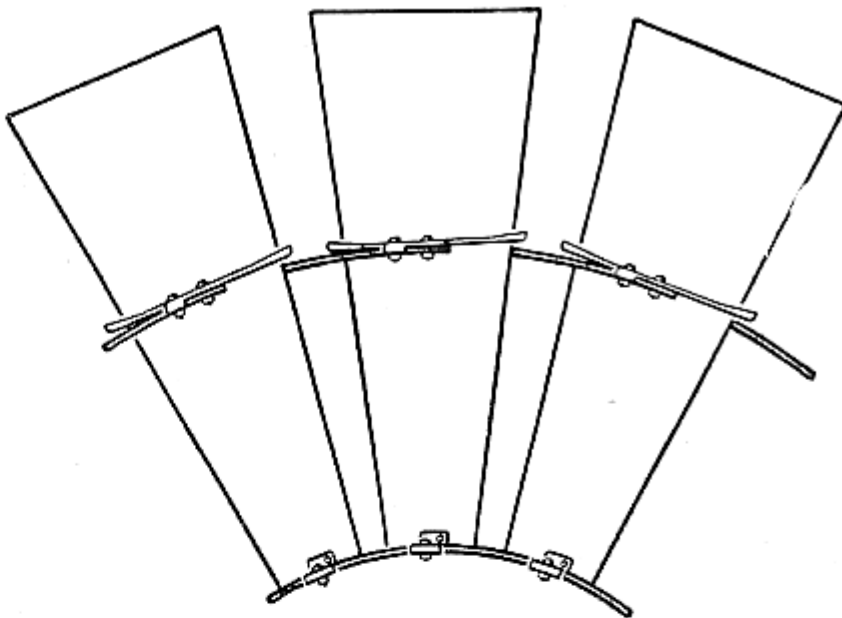

(5) Put in the bolts, fitting Spring Washers under the nuts.

(6) Take another Fan in your left hand, holding it as before and push the long end of the ring through it. Push it through until the Bracket lines up on the middle pair of holes. Put the bolts in, fitting Spring Washers under the nuts.

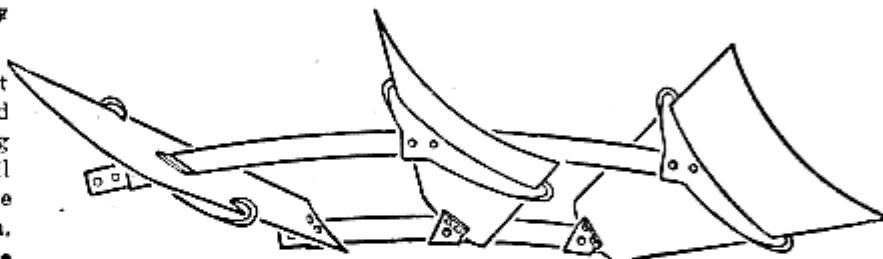

One Section of the Wheel.

(7) Put on the third fan in a similar manner. Stand the section of Fans on end.

(8) Bolt on the Inner Ring Section, making sure that the short end of both the Inner and Outer Rings are on the same end of the section of the wheel. Fit Spring Washers under all the nuts.

(9) Assemble the rest of the sections of the wheel.

(10) Tighten all nuts on the wheel sections.

(11) Put white lead or heavy paint on the thread and then screw the Wheel Arms into the Wheel Hub. The end with the square formed on it screws into the Hub. Do not fit any washers between the Arms and the Hub.

(12) Do not start to put the Fan Sections on if there is not at least four hours of daylight left. It would be very risky if the wheel was left partly assembled overnight.

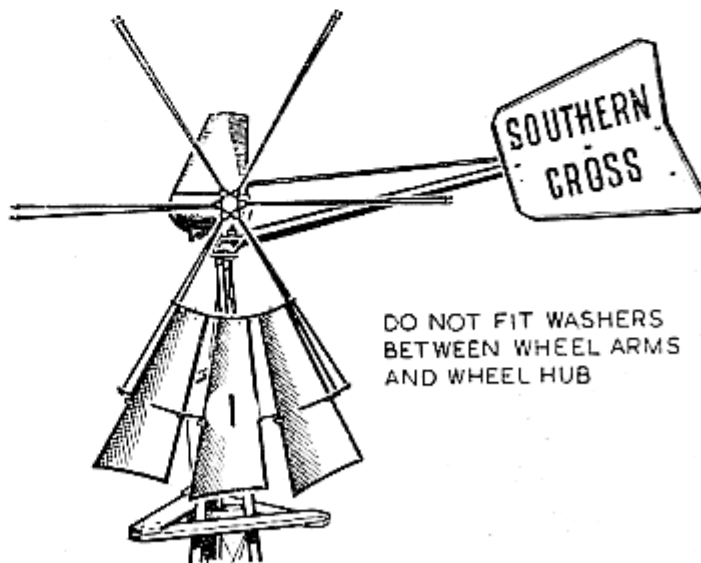

Fitting First Section to Wheel—6ft., 8ft., 10ft. and 12ft. Mills



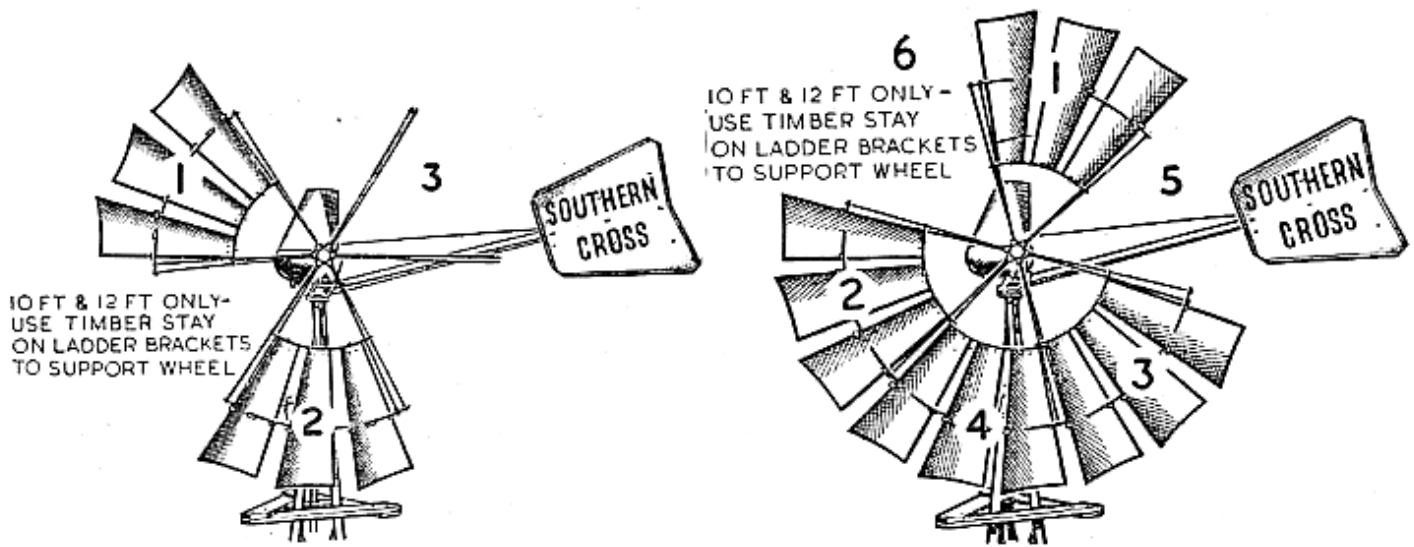

Assembling Wheel—6ft., 8ft., 10ft. and 12ft. Mills

**6ft., 8ft., 10ft. and 12ft. Mills Only.**

- (13) **1st Section:** Refer to illustration, "Fitting 1st Section to Wheel, 6ft., 8ft., 10ft. and 12ft. Mills." Pull up a Fan Section (previously assembled) and turn it so the hollow side of the Fans face outwards from the mill. Fit the Fan Section with one front Arm and one back Arm fitting into each end of the Outer Ring. Screw nuts a few turns on to the arms to hold the fan section in place. When fitting the Fan Sections, see that all the Front Arms are fitted on the same side of the Back Arms (Refer to illustration "Wheel Arm Positions"). In the illustration, when each pair of Arms is at the bottom of the Wheel, the Front Arm is on the right if the wheel is viewed from the front, or on the left if viewed from the tower platform.
- (14) **2nd Section:** Turn the wheel to the right, pushing the 1st Fan Section up as shown in the illustration, "Assembling Wheel, 6ft., 8ft., 10ft. and 12ft. Mills." For 10ft. and 12ft. Mills, put a piece of timber between the Ladder Brackets and under the Wheel Arm to support the 1st Fan Section. Pull up another Fan Section and attach it in the same way as the 1st Section.
- (15) **3rd Section:** Turn the wheel again and fit the 3rd Section. The two sections already fitted will balance each other on top.
- (16) **4th Section:** (Refer to illustration, "Assembling Wheel, 6ft. 8ft., 10ft. and 12ft. Mills.") The Wheel now consists of three sections equally spaced. This leaves three spaces. Turn the wheel until one of these spaces is at the bottom and fit another section. It will be necessary to remove the nuts from the wheel arms to do this. The Outer Ring on the 4th Section fits on to the Arms outside the two sections already fitted. For 10ft. and 12ft. Mills support the wheel with a timber stay through the Ladder Brackets.
- (17) **5th and 6th Sections:** Turn the wheel and fit these sections in the same way as the 4th Section.
- (18) Now go around the wheel and remove in turn each nut from the ends of the wheel arms and replace with a spring washer under the nut. Only screw the nuts on a few turns when replacing them.

**14ft. Mill Only.**

- (19) **1st Section:** Pull up a Fan Section (previously assembled) and turn it so the hollow side of the fans faces outward from the mill. Fit the Fan Section with one front arm and one back arm fitting into each end of the Outer Ring. Screw nuts a few turns on to the arms to hold the Fan Section in place. When fitting the Fan Sections, see that all the Front Arms are fitted on the same side of the Back Arms (Refer to illustration "Wheel Arm Positions"). In the illustration when each pair of Arms is at the bottom of the Wheel, the Front Arm is on the right if the wheel is viewed from the front, or on the left if viewed from the tower platform.

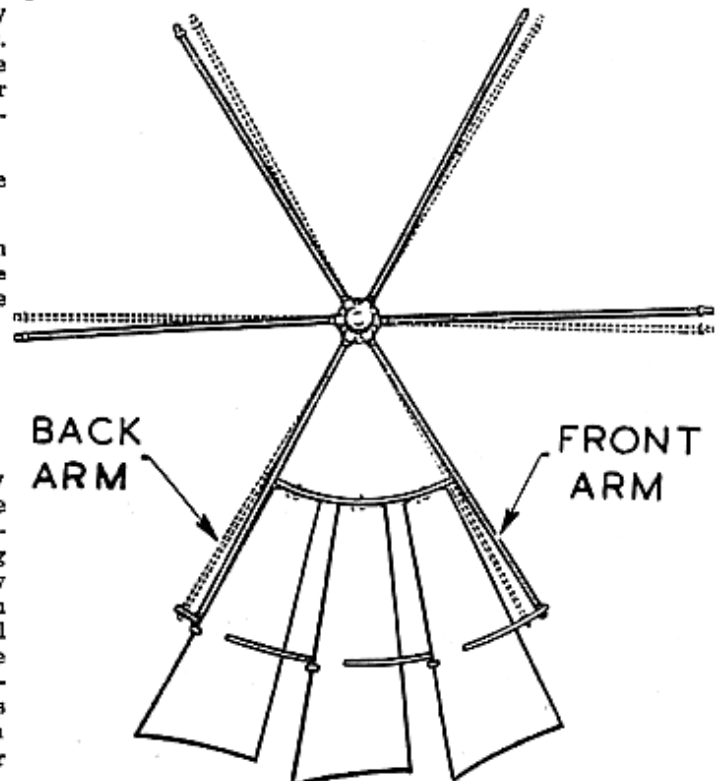

Wheel Arm Positions.



(20) **2nd Section:** Turn the wheel until the section marked 2 on the illustration, "Assembling Wheel, 14ft. Mill" is at the bottom. This will put the 1st Section at the top. Put a timber stay between the Ladder Brackets and under the Wheel Arms to support the wheel. Fit another Fan Section in the same way as the 1st Section was fitted.

(21) **3rd Section:** Turn the wheel until the section marked (3) is at the bottom and fit another section.

(22) **4th Section:** Turn the wheel until the Section marked (4) is at the bottom. The three sections already fitted will balance each other. Fit another section.

(23) **5th Section:** The wheel now consists of four Fan Sections equally spaced. This leaves four spaces. Turn the wheel until one of these spaces is at the bottom and fit another section. It will be necessary to remove the nuts from the wheel arms to do this. The Outer Ring of the 5th Section fits on to the Arms outside the two sections already fitted.

(24) **6th, 7th and 8th Sections:** Add the 6th, 7th and 8th Sections in the same manner as the 5th Section. Before fitting the 7th Section in place, tie a piece of wire across the space for the 8th Section. This will carry the weight of the rest of the sections. It may be necessary to adjust the wire by twitching it so as to space the Arms correctly. (Refer illustration, "Assembling Wheel, 14ft. Mill.")

(25) Now go round the Wheel and remove in turn each nut from the ends of the Wheel Arms and replace with a spring washer under the nut. Only screw the nuts on a few turns when replacing them.

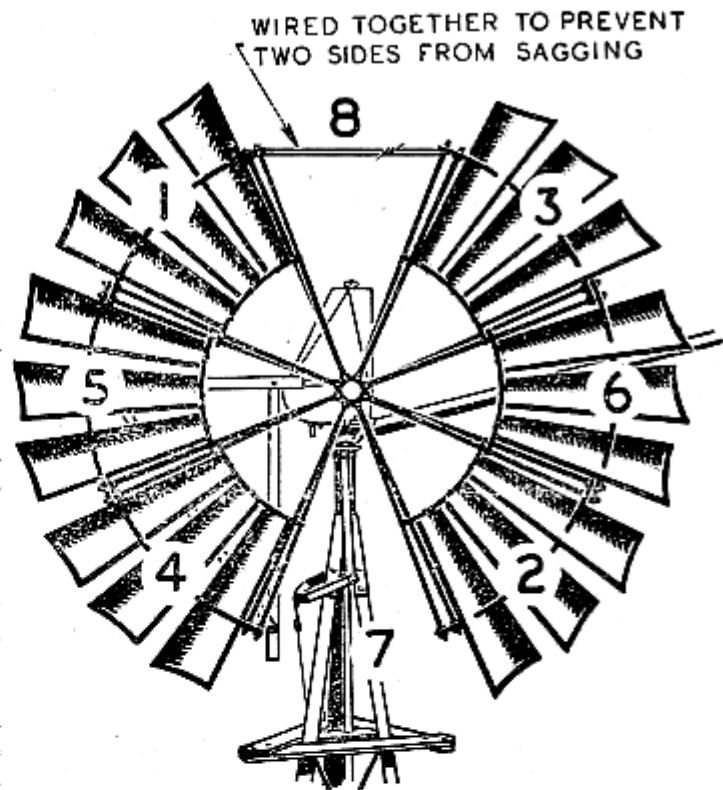

Assembling Wheel—14ft. Mill.

## All Sizes of Mills

(26) Fit the Inner Ring Brackets as shown in the illustration, "Inner Ring Bracket." See that the laps on the Inner Ring Joints are the same as those on the Outer Ring before bolting the Inner Ring to the Bracket. Fit a spring washer under each of the nuts on the bolts holding the Inner Ring to the Bracket.

(27) Now tighten the nuts on the ends of the Wheel Arms. Go round the wheel several times, tightening the nuts up a little at a time so the strain comes evenly on all the arms.

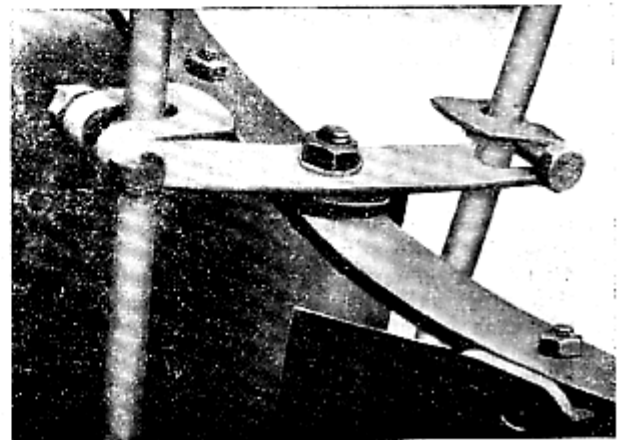

Inner Ring Bracket.

## Oiling the Mill.

- (1) When the erection of the mill is complete, fill the Gearbox up to the oil level mark with Southern Cross "IZ" Pattern Windmill Oil. There is a ledge on the outside and inside of the Gearbox indicating the oil level, and it is important that this level is not exceeded, as it will make the Gears splash oil over the sides. Smear a small quantity of grease on the face of the reefing collar so that the mill will pivot freely when reefed.
- (2) Remove the plug in the Wheel Hub and pour in at least an eggcupful of oil. Then replace plug.
- (3) With the Helmet off, rotate the wheel a few times to see that everything is clear. Make sure that the Crosshead Oil Rings, No. 65, are quite free in their guides and touch the gearwheels, so that they carry oil up to the Crosshead Pin. They may have been bent out of round during transit.
- (4) Put on the Helmet and see that it fits down. Then tighten the Wing Nut on top.
- (5) Every six months apply a small quantity of grease to the face of the reefing collar.
- (6) Every twelve months after erection the oil in the mill should be drained by screwing out the drain plug in the bottom of the Gearbox. Fresh oil should be put in to the level shown on the Gearbox.
- (7) The correct grade of oil is essential to the working of this mill, so do not use any other oil than "IZ" PATERN SOUTHERN CROSS WINDMILL OIL, which is obtainable either from the Southern Cross distributor in your district, or, if he doesn't stock it, from any office of the Southern Cross Organisation.

## To Connect Pump

- (1) Refer to Parts Illustration on Page 29, Reef Mill and remove Helmet. Remove Pump Rod Pin, No. 54, from Crosshead, No. 16. Slide Pump Rod No. 103 up inside Stub Tower into position in Crosshead, and then insert Pump Rod Pin and Cotter Pin. Replace Helmet.

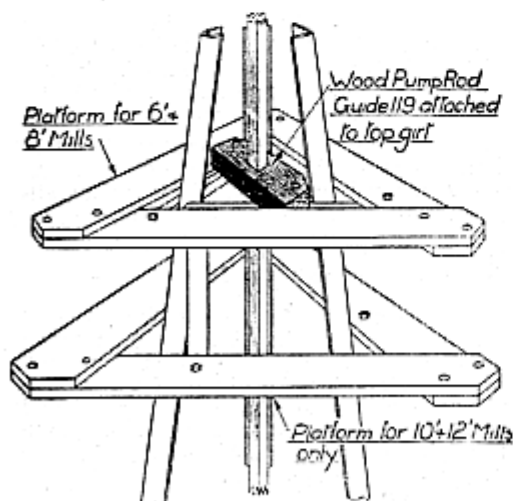

Fitting Wood Pump Rod Guide.

- (2) Fit Wood Pump Rod Guide to Top Girt using hook bolts supplied, as shown in the illustration, "Fitting Wood Pump Rod Guide."
- (3) Fit the Wood Pump Rod through the hole in the Pump Rod Guide and bolt it to the Pump Rod, No. 103.
- (4) If any further lengths of wood pump rod are to be fitted, they are connected using the fish plates and bolts supplied. Each length of wood Pump Rod above the Packing Box or Spill Piece should be fitted with a wood Pump Rod Guide as near to the middle of each length as possible. Wood Pump Rod Guides are fitted in the same way as the one which has already been fitted for the top length of wood Pump Rod.
- (5) Before finally connecting up the Pump Rod, read No. 9 on Page 18.
- (6) To connect the Wood Pump Rod to a steel Bore Pump Rod with screwed joints, screw a coupling on to the steel Pump Rod and then screw on the Mill Rod Connection supplied with the mill. The connection between the wood Pump Rod and the Plunger Rod of a Syphon Pump is made in the same way.
- (7) If the steel Bore Pump Rod is fitted with "Quick Action" Joints, fit the Pump Rod Top End supplied, and then make the connection as in (6) above.
- (8) If the mill replaces an old mill it may be necessary to use the old original connection.

- (9) **IMPORTANT:** This operation must be carried out otherwise the Pump Plunger will hit the bottom of the Pump. Turn the mill until it is at the bottom of its stroke. Lift the Bore Pump Rod 1 inch and mark the position for the connection. Cut the wood Pump Rod to suit, if necessary; bore holes to suit the connection and bolt together.
- Draw Plunger Pumps:** Southern Cross Draw Plunger Pumps have to be lifted either 1 inch or 7 inches when connecting the bore rod to the mill rod. Draw Plunger Pumps installed between 1958 and 1963 have to be lifted 1 inch. Pumps installed prior to 1958 and after 1963 have to be lifted 7 inches.
- If in doubt about a pump, screw the pump plunger down on to the bottom valve assembly and raise both assemblies to the top of the pump. Look into the bottom of the pump barrel and if there is a wide, shallow recess (1/32in. deep), approximately 6 inches above the bottom, the pump rod has to be lifted 7 inches when connecting up. On pumps without this recess, the pump rod has only to be lifted 1 inch when connecting up.
- (10) Make sure that Wood Guides and Pump Rods are exactly in line and do not bind anywhere. If these are out of line at all they will considerably increase the load, especially on the smaller Mills.
- (11) Before unreefing the Mill turn the Wheel round a few times by hand to see that the Pump clears, and rotate the Mill completely round on its Turntable.
- (12) So as to prevent excess wear on the Wood Rod and Guides, they should both be greased regularly.

## DISCHARGE PIPE STAYS

Pipe Stays should be fitted to the discharge pipe to stop any sway of the pipe and consequent wearing of the Pump Rods.

Except in the case of an installation discharging at ground level (including side delivery Syphon Pump installation) always fit one Pipe Stay as close as possible to the top of the Spill Piece, and if the discharge pipe is more than 20 feet above ground level, fit one Pipe Stay for each length of piping above ground level. Where more than one Pipe Stay is being fitted, space them as evenly as possible between the ground and the Pipe Stay at the top of the Spill Piece.

The 3in. x 2in. Pipe Stays are fitted with the 3in. face to the girts and are bolted to the girts with the hook bolts supplied. To attach the discharge pipe to the Pipe Stays, drill holes to suit and bolt together with the U bolts supplied.

## Air Chamber

An air chamber is used to keep the water flowing evenly through the delivery pipe instead of being delivered as separate surges after each up-stroke of the pump. Due to the even flow of water in the delivery pipe, the pump does not have to make a big increase in the rate of flow on each up-stroke, and consequently there is less wear and tear on the pumping plant.

The air chamber should be fitted to the delivery pipe as close as possible to the pump. Where the pump is down a bore, fit the air chamber as close as possible to the top of the bore. A check valve must be fitted on the delivery side of the air chamber to prevent water in the pipe running back when the plug in the air chamber is opened for draining: It is also advisable to fit a check valve on the inlet side of the air chamber in order to relieve the pump valves of the pressure of the chamber.

The air chamber will only be effective while there is air in it to cushion the flow of water. **THE AIR CHAMBER IS USELESS IF IT IS FULL OF WATER.** Due to pressure in the delivery pipe, the air in the air chamber is gradually absorbed by the water and the air chamber becomes ineffective.

A plug is fitted to the bottom of the air chamber to drain the water from it, and the chamber should be drained periodically. Periods between draining will vary with different installations, and experience will indicate how often it is necessary.

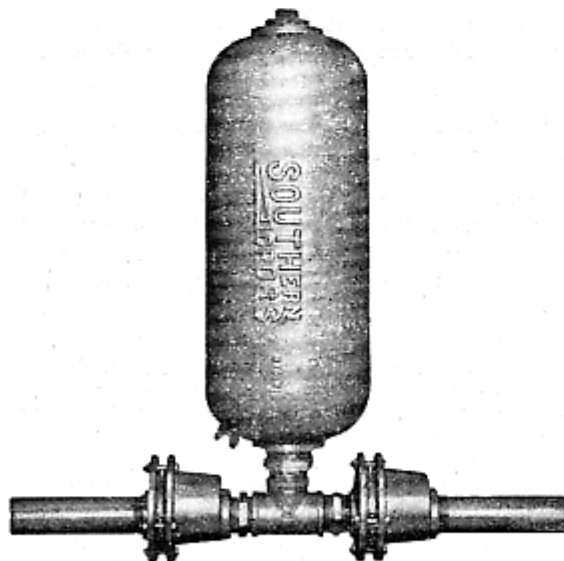

Fitting Air Chamber

## Suction Chamber

The purpose of a suction chamber is to provide an even flow of water in the suction pipe to Syphon Pumps instead of a flow which stops on the down-stroke of the pump. The suction chamber also acts as a reservoir and helps supply water which will flow immediately behind the plunger on the up-stroke, and so prevents water hammer. During the downstroke of the pump the water in the suction pipe keeps flowing and replaces the reservoir of water in the suction chamber.

The suction chamber has a cushion of air as in an air chamber, but unlike the air in the air chamber it is not absorbed by the water—instead the size of the air cushion increases. The top should be screwed off the suction chamber periodically and water poured in until the chamber is three-quarters full, leaving one quarter of the chamber as an air cushion. Periods between fillings will vary with different installations, and experience will indicate how often it is necessary.

**IMPORTANT.**—Special attention should be given to a Windmill during the first month or so after erection. Bolts may stretch and work loose while the Mill is new, and they should be gone over once or twice and tightened up.

## GENERAL INSTRUCTIONS

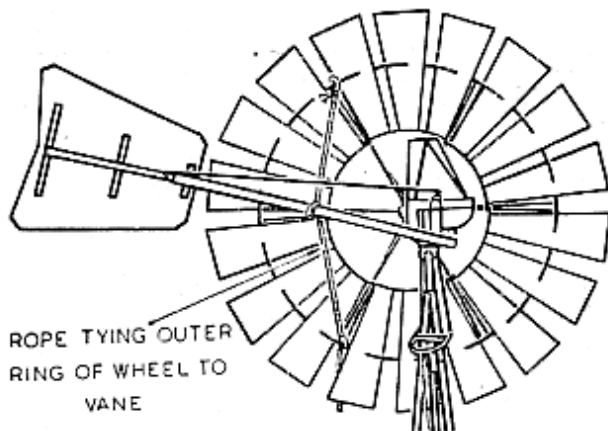

ROPE TYING OUTER RING OF WHEEL TO VANE

*Tying Wheel to Vane.*

### RAISING AND LOWERING PIPE COLUMNS

When rigging a pulley block in the tower for raising or lowering the piping, it is important to observe the following points:—

1. Separate slings should be used on each leg, and they should be as high up in the tower as possible.
2. The slings should be long enough so they hang almost vertically when the pulley block is fitted on the lower end. Refer illustration, "Correct", at right.

Do not under any circumstances connect the slings as shown in "Incorrect" as they tend to buckle the tower legs and this could cause the tower to collapse.

NOTE: Any damage to the tower caused by the use of slings or other lifting equipment is not covered by the "Warranty" on the Windmill.

### Tying Wheel and Clamping Pumprod

1. Before starting any work on the Mill, reef it and then turn the Wheel by hand until the Pump Rod is about 1 in. from the top of the stroke.
2. Then tie the Wheel to the Vane as shown in the illustration, "Tying Wheel to Vane". **Never tie the Wheel to the Tower**, as this would prevent the Mill from revolving on its Turntable should the wind change.
3. If the Mill is connected to the Pump, clamp the Pump Rod on top of the Delivery Pipe to prevent the Rod from slipping down. Use a hand vice or some similar clamp.

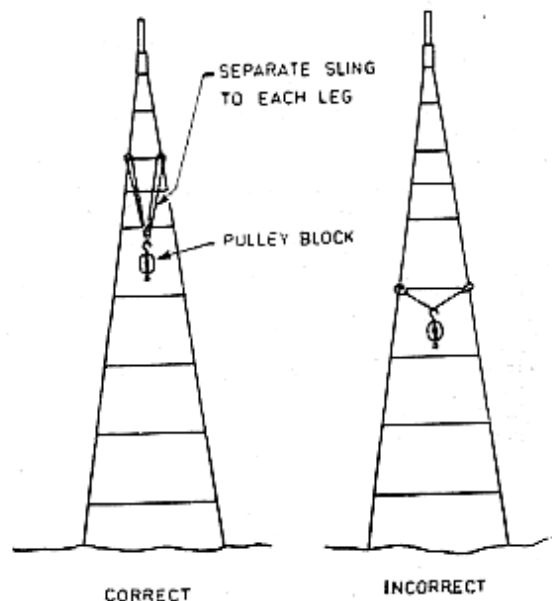

CORRECT

INCORRECT

### To Change the Stroke from One Long to the Other Long

(Refer to illustration, "To Change the Stroke".)

1. Tie the wheel and clamp the Pump Rod as shown in illustration, "Tying Wheel to Vane".
2. Remove Cotter Pins from end of Crosshead Pin, No. 56, and by sliding the Pin sideways, disconnect the Connecting Rods, No. 9.
3. Remove Cotter Pins from Connecting Rod Retaining Plugs, No. 11, and remove the Plugs.
4. The Connecting Rods, No. 9, may now be removed.
5. Untie the Wheel and turn it until the other pair of Long Stroke Bearings is at the top and replace Connecting Rods in these Bearings.
6. Then turn the Wheel again until the top ends of the Connecting Rods correspond with the Crosshead Pin Holes. Replace Crosshead Pin and tie the Wheel to the Vane again.
7. Replace Connecting Rod Retaining Plugs with Cotter Pins, and put Cotter Pins back into Crosshead Pin. Be sure that the ends are spread properly.
8. The clamp on the Pump Rod may now be removed. The Wheel untied, and, after turning round by hand, let the Mill into the wind.

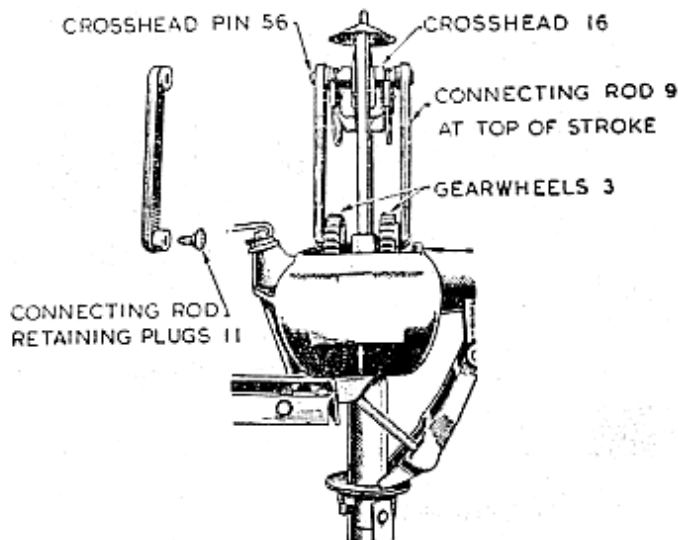

*To Change the Stroke.*

## To Change the Stroke from Long to Short

Refer to the illustration, "To Remove the Gearwheels," and follow out the instructions as set out under the heading, "To Remove Gearwheel," up to and including paragraph four. Then continue as follows:—

- (5) Turn the Gearwheels so that the pair of Short Stroke Bearings are at the top, and replace the Connecting Rods in these Bearings.
- (6) Replace the Gearwheels and make certain that the two Connecting Rod Bearings are in line. It is important to remember that the Connecting Rods must be at the top of the stroke when removing and replacing the Gearwheels. When replacing the Gearwheels, make sure the key on the Gearwheel Bearing engages in the slot in the Gearbox.
- (7) Replace the Gearwheel Bearing Clamp, No. 92.
- (8) Put the Crosshead Pin, No. 56, back into position by reversing the process for removing it.
- (9) The clamp on the Pump Rod may now be removed, the Wheel untied, and, after turning round by hand, let the Mill into the wind.

## To Remove Gearwheels.

If it is necessary at any time to remove the Gearwheels, proceed as follows. (Refer to illustration, "To Remove the Gearwheels," below.):—

- (1) Tie up the Wheel and clamp the Pump Rod on top of the delivery pipe.
- (2) Remove Cotter Pins from Crosshead Pin, No. 56, and then, by sliding the Crosshead Pin sideways, disconnect the Connecting Rods, No. 9.
- (3) Now remove setscrew from Gearwheel Bearing Clamp, No. 92, and remove the Clamp.
- (4) Untie the Wheel and turn it until the Connecting Rods are at the top. Then lift the Gearwheels out of the Gearbox.
- (5) Remove the cotter pins and the shaft can then be driven out of the gearwheels, using a piece of brass bar as a drift.

It is important to remember that the Connecting Rods must be at the top of the stroke when removing or replacing Gearwheels.

When the Gearwheels are replaced in position, make sure that the two Connecting Rod Bearings are in line and the key on the Gearwheel Bearing engages in the slot in the Gearbox.

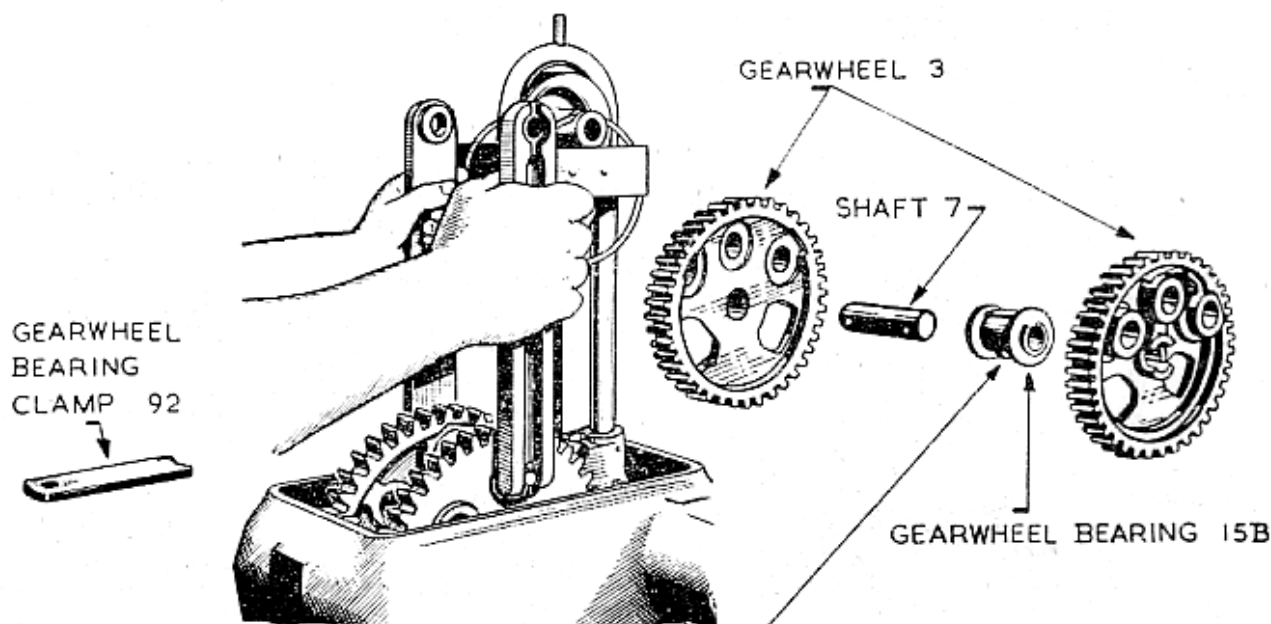

KEY ON BEARING MUST FIT INTO RECESS IN GEARBOX .

*To Remove the Gearwheels.*

## To Replace Bearings

**GEARWHEEL BEARING:** If the Gearwheel Bearing is the only one being replaced, follow instructions given in section, "To Remove Gearwheels".

### MAIN AND PINION BEARINGS:

- (1) Clamp the pump rod. (Refer section, "Tying Wheel and Clamping Pump Rod".)
  - (2) Remove the Inner Ring Brackets and the Fan Sections from the Wheel and lower them to the ground. Then screw the Wheel Arms out of the Wheel Hub.
  - (3) Remove the Gearwheels. (Refer section, "To Remove Gearwheels".)
  - (4) Unscrew the plug from the Wheel Hub and turn Wheel Hub until hole is at the top. Insert a screwdriver and screw out the Oil Collector Peg.
  - (5) Undo the Pinion Locking Screws and slide the Main Shaft out of the Gearbox. A spanner to fit these locking screws can be obtained on loan from your nearest SOUTHERN CROSS Sales Office or distributor.
  - (6) Lift the Pinions, Oil Scraper, and Oil Return Spring out of the Gearbox.
  - (7) Undo the Main Bearing Locking Screw, insert a long bolt or hook through the bearing and pull it out of the Gearbox.
  - (8) Insert a long bar through the Main Bearing Hole in the Gearbox and tap the Pinion Bearing out.
  - (9) Fit the new Pinion Bearing with the collar on the side away from the wheel and tap it into place, making sure the key on the bearing engages in the cast slot in the Gearbox.
  - (10) Examine the new Main Bearing and it will be found that there is a spiral groove inside the bearing running to one end. Insert this end in the Gearbox, seeing that the hole for the Main Bearing Locking Screw is on the top and will line up when the bearing is in position. Lightly tap the bearing into position and fit the Main Bearing Locking Screw.
  - (11) Replace the Oil Return Spring, the Oil Scraper, and the Pinions. Oil the Main Shaft and then slide it back into position.
- IMPORTANT:** When locking pinions to the shaft, refer section, "To Tighten Pinion Locking Screws".
- (12) Screw in the Oil Collector Peg and then pour about an eggcup full of oil into the hole in the Wheel Hub. Then replace the plug in the Hub.
  - (13) The rest of the parts can be fitted in the reverse order to which they were removed.

## To Fit New Pinions

- (1) Clamp the pumprod. (Refer Section, "Tying Wheel and Clamping Pump Rod".)
- (2) **6ft., 8ft., and 10ft. Mills:** Erect a gin pole from the ground to extend above the top of the wheel. Tie a hemp rope sling around the wheel hub and lift the sling on the gin pole to take the weight of the wheel.  
**12ft. and 14ft. Mills:** Remove the inner ring brackets and fan sections from the wheel and lower them to the ground. Then screw the wheel arms out of the wheel hub.
- (3) Remove the gearwheels. (Refer Section, "To Remove Gearwheels".)
- (4) Unscrew the plug from the wheel hub and turn the wheel hub until the hole is at the top. Insert a screw driver and screw out the oil collector peg.
- (5) Undo the pinion locking screws and slide the mainshaft through the main bearing until the pinions are free.
- (6) Remove the locking screws from the new pinions and thoroughly clean the threads in the pinions and threads on the locking screws, using solvent or petrol. Hold the pinions in position and slide the mainshaft back to its original position. Pinions are fitted with their bosses facing away from the pinion bearing. The oil scraper fits over the boss of the pinion nearest the wheel hub.
- (7) Two flat sections are provided at each position where the pinion locking screws tighten down onto the mainshaft. Turn the pinion furthest from the wheel hub on the mainshaft until both flats are visible through the locking screw holes. Screw in the pinion locking screws and attach the pinions to the mainshaft.  
**IMPORTANT:** Refer section "To Tighten Pinion Locking Screws".
- (8) Screw in the oil collector peg and pour about an eggcup full of oil into the hole in the wheel hub. Refit plug in the wheel hub.
- (9) Reassemble the rest of the parts in the reverse order to which they were removed.
- (10) **6ft., 8ft., and 10ft. Mills:** Remove lifting tackle and gin pole.
- (11) Unclamp the pump rod.

## To Tighten Pinion Locking Screws

The locking screw holes in the pinions are not located in line with the centre of the shaft—they are offset, and locking screws tighten onto the sides of the flats on the shaft. For this reason, the method of tightening the locking screws must be followed carefully. Failure to do this could allow the pinions to work loose and damage the mill.

- (1) Tighten one locking screw in the pinion to finger tightness only. Turn the pinion to and fro on the shaft, if possible, to check the locking, and, if necessary, tighten the locking screw further, until no movement can be felt.
- (2) Tighten the locking screw firmly, but do not overtighten. Then undo the locking screw one-twelfth of a turn (30°).
- (3) After loosening the first locking screw one-twelfth of a turn, leave it in this position while screwing the other locking screw in and tightening it firmly.



AMENDMENT TO INSTRUCTIONS

**TO FIT NEW PINIONS**

- (1) Turn the Wheel until the plug in the Wheel Hub is to the top and remove the plug. Insert a screw driver and screw out the oil collector peg.
- (2) Turn the wheel so the plug hole in the wheel hub is to the bottom.
- (3) Clamp the pumprod with the wheel in position as in (2) above. (Refer Section "Tying Wheel and Clamping Pump Rod".)
- (4) 6ft., 8ft., and 10ft. Mills: Erect a gin pole from the ground to extend above the top of the wheel. Tie a hemp rope sling around the wheel hub and lift the sling on the gin pole to take the weight of the wheel.  
12ft., and 14ft. Mills: Remove the inner ring brackets and fan sections from the wheel and lower them to the ground. Then screw the wheel arms out of the wheel hub.
- (5) Remove the gearwheels. (Refer Section "To Remove Gearwheels".)
- (6) Remove the locking screws from the new pinions and thoroughly clean threads in the pinions and threads on the locking screws, using petrol or solvent.
- (7) Undo the pinion locking screws and slide the mainshaft through the main bearing until the pinions are free.
- (8) Hold new pinions in position and slide the mainshaft back to its original position. Pinions are fitted with their bosses facing away from the pinion bearing. The oil scraper fits over the boss of the pinion nearest the wheel hub.
- (9) Two flat sections are provided at each position where the pinion locking screws tighten down onto the mainshaft. Turn the pinion, furthest from the wheel hub, on the mainshaft, until both flats are visible through the locking screw holes.
- (10) Fit a twist drill of the size shown below, down through the hole in the pinion and the shaft to act as a "dummy" pin. Do not use one of the tension pins supplied.

SIZE MILL

6ft.  
8ft. and 10ft.  
12ft. and 14ft.

TWIST DRILL SIZE

3/16 in.  
1/4 in.  
5/16 in.

- (11) Pull the wheel hub in towards the gearbox so the wheel hub is in hard against the end of the gearbox.
- (12) Estimate the greatest number of shims which will be required to be fitted between the side of the pinion which is pinned to the shaft and the face of the pinion bearing, to leave a minimum clearance of .005 inch.
- (13) Remove the twist drill and slide the wheel hub outwards to release the pinion, furthest from the wheel hub.
- (14) Place the correct number of shims, as estimated, onto the shaft and refit the pinion.
- (15) Check that locking screw holes in pinions are over the flat sections of the shaft and fit a tension pin through each pinion and the shaft. Locate the pin so the distance from the top of the teeth to the pin is as shown in the illustration "Locating Tension Pin", below.

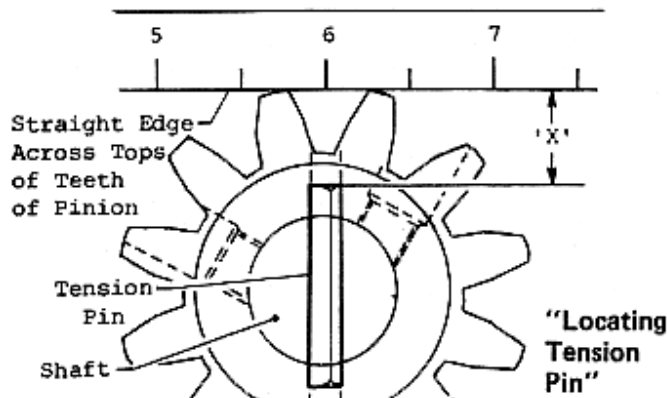

DIMENSION 'X'	
SIZE MILL	DIMENSION
6 ft.	9/16 in.
8 ft.	1-1/4 in.
10 ft.	1-1/16 in.
12 ft.	1-1/4 in.
14 ft.	1-1/4 in.

- (16) Coat threads of locking screws with 'Nutlock' and screw them into the pinions until they are against the flats on the shaft. Tighten locking screws evenly, using a locking screw spanner.  
**CAUTION:** Only Loctite 'Nutlock' should be used on threads. The use of some Loctite products may cause permanent locking of the screws, so they can never be loosened, should the removal of the pinions ever become necessary.
- (17) Fit a short piece of tube or pipe to the locking screw spanner for added leverage, and tighten locking screws securely.
- (18) Reassemble the mill, fitting parts in the reverse order to which they were removed. Unclamp the pump rod.
- (19) Turn the wheel so the plug in the wheel hub is to the top and refit the oil collector peg. Pour about an eggcup full of oil into the hole in the wheel hub and refit the plug.
- (20) Refill the gearbox with oil.

No. Per Mill	6 Ft. IZA	8 Ft. IZB	10 Ft. IZC	12 Ft. IZD	14 Ft. IZE	Name of Part
2	IZA 5D	IZB 5D	IZC 5D	IZD 5D	IZE 5D	Pinion
1	IZA 51C	IZB 51C	IZC 51B	IZD 51B	IZE 51B	Main Shaft
As Req'd.	IZA 193	IZB 193	IZC 193	IZD 193	IZE 193	Pinion Shim
2	1 1/4 in. x 3/16 in.	1 1/4 in. x 1/4 in.	2 in. x 1/4 in.	2 1/2 in. x 5/16 in.	2 1/2 in. x 5/16 in.	Pinion Retaining Pin (Tension Pin)

- (4) **When Attaching Pinions to Existing Shaft:** After tightening both locking screws firmly, check for correct location of the locking screws. Remove one screw from the pinion and, by holding the pinion and wheel hub, try to turn the pinion on the shaft. If no movement is felt, the location is correct. Coat the threads of the locking screw which was removed, with "Nutlock", and screw it in again. Fit a short piece of tube or piping to the locking screw spanner for added leverage, and tighten the locking screw securely. Remove the other locking screw, coat it with "Nutlock", and screw it into the pinion. Tighten locking screw securely.
- (5) **When Attaching Pinion to a New Shaft:** After tightening both locking screws firmly, check if location of the screws is correct. Remove one locking screw and, looking into the locking screw hole, see if the marking on the shaft is a full circle. If it is only part of a circle, repeat the locating procedure, being careful to loosen the first locking screw *one-twelfth of a turn*, as in (2). When the locking screw makes a circular mark on the shaft, coat its threads with "Nutlock" and screw it in securely. Remove the other locking screw and coat it with "Nutlock" and screw it in securely. Fit a short piece of tube or pipe to the locking screw spanner for added leverage when tightening the locking screws.
- CAUTION:** Only Loctite "Nutlock" should be used on threads. The use of some other Loctite products may cause permanent locking of the screws so that they can never be loosened should the removal of the pinions ever become necessary.
- (6) Using the same procedure, attach the remaining pinion to the mainshaft.

## Trouble with Windmills.

One of the most common causes of bad results from Windmills is that the Tower is not erected plumb; that is, the Tower is not exactly vertical. This manifests itself in many ways. The main ones are:—

- (1) That the Mill will not pivot freely to face light winds, but rather hangs facing one direction; and
- (2) That when the wind is blowing from the direction which the Mill most readily faces it will not govern correctly, while with a wind from other directions it will govern before it should.

The reason for this is that when the Tower is not vertical the Turntable is not level, and the weight of the Wheel tends to turn it naturally to the lowest side. It takes a greater pressure on the Vane to turn the Wheel away from this low side, since it has to move, in effect, uphill. When the Mill is hanging on this low side it takes a greater wind pressure to move the Wheel out of the wind when it should start to govern, because there is added to the normal resistance that which is offered by the rise of the Turntable, and conversely when the Mill is pumping in a fair wind from some other direction than the low side, it will govern more easily because the normal resistance is reduced by the natural tendency of the Wheel to turn towards the lowest part of the Turntable.

The best way to test whether a Tower is plumb is to pack up a level on the crankcase until the bubble is exactly central, and then turn the Mill round on its Turntable and watch if there is any appreciable change in the position of the bubble.

## Knocks in Windmills.

After a Geared Windmill has been working for some time a knock is generally heard. This knock is quite natural, as it is due to the slight backlash in the Gears, and when the Mill gets to the top of the stroke the load is taken off the Gears by the weight of the Pump Rods, and the Gears knock over on to the other side of the teeth, and the weight of the Pump Rods helps to drive the Wheel during the down stroke.



## Pump Troubles

This section has been written with a view to assisting in diagnosing and remedying pump troubles. It should be read right through carefully before commencing to attend to a Pump. Everyone should be careful when a Pump is not working, or working indifferently, to observe it while the Mill is working, before commencing to pull it up. This observation of the symptoms will most usually enable the trouble to be seen immediately.

The most usual signs of trouble encountered with Well or Bore Pumps are:—

- (1) Pump not delivering any water.
- (2) Pump delivering a steady supply but less than previously.
- (3) Pump delivering a full supply when started, but output gradually diminishing as pumping is continued, occasionally accompanied by:—
- (4) Pump making slight knocking noise and water splashing out over the Spill Piece.
- (5) Or loud knocking noise on down stroke, causing whole Mill to resound accompanied by diminished supply, or none at all.
- (6) Water receding in Pipes when Pump is stopped, and needing some strokes before water reaches the top when it is started again.
- (7) Spasmodic action; Pump delivering full supply at times and abruptly ceasing, and perhaps starting again just as abruptly.

**No. 1 may be caused by:—**

- (a) Broken Pump Rods or Joints.
  - (b) Worn-out Leathers.
  - (c) Plunger Valve holding up.
  - (d) Bottom Valve holding up.
  - (e) End of Suction above water, or hole in Suction Pipe above water level.
  - (f) Leakage in Discharge Pipe between Pump and T-piece.
  - (g) Suction Pipe completely blocked.
  - (h) Suction Pipe too long; that is, Pump too far above water level.
- (a) If the Rods are broken and there is no other defect, the Pipes will stay full of water to the T-piece. Usually it can be decided that the Rods are broken by turning the Windmill by hand. The absence of any appreciable resistance to the turning will indicate broken Rods.
  - (b) Worn Leathers do not usually cause a complete cessation but rather a steadily diminishing supply. Knowledge of the length of time the leathers have been in use is a guide to their condition. It is advisable to study the other symptoms and if they can be eliminated it may be decided that worn Leathers are the cause of the trouble; that is to say, that if the diminution has been continuous over a period and there is no knocking or splashing of water over the Spill Piece and the Pipes stay full when the Pump is stopped, worn Leathers are certainly the cause.
  - (c) When the Plunger Valve is held up by some obstruction, the water in the Discharge Pipe will stand at the level of the T-Piece with practically no movement when the Pump is working. A few sharp blows on the rods while it is working may cause the Valve to seat correctly and commence pumping. This, however, is not a permanent remedy, and it is advisable to get the Pump up and fix the Valve at the first opportunity.
  - (d) If the bottom Valve is held up the water in the pipe will rise and fall with the Rods. The remedy is to get the Pump up and remove the obstruction.
  - (e) A hole in the Suction Pipe above water level or the suction being completely above the water will cause the Pump to deliver air instead of water.
  - (f) A leakage in the discharge is not usually so large as to cause complete stoppage in delivery, but rather a reduction. A split pipe will be indicated by diminished output from the Pump, and when the Pump is stopped the water in the Pipes will recede. (See Case 2c.)
  - (g) If the Suction Pipe is choked, no water at all can enter the Pump.
  - (h) No Pump should be more than 20 feet vertically above water level; less if possible. If a Pump has a long Suction Pipe and the water level recedes to 25ft. or 30ft. below the Pump, the delivery will cease completely or partially and symptoms will be as in Case 5, on Page 24.

**Case No. 2 may be caused by:—**

- (a) Worn Leathers.
  - (b) Worn Valves.
  - (c) Leakage in Discharge Pipe.
  - (d) Diminished supply in bore.
- (a) If, when the Pump is stopped, the water stands at the top of the Pipe, the cause of a diminished supply is most usually worn Leathers, or a worn Plunger Valve, or both. Pull the Pump out and renew the Leathers and examine the Valves. See Cases (b) and (c).

- (b) If the Leathers are good and the valves only are leaking, then the water will recede when the Pump is stopped.
- (c) A leakage in the Delivery Pipe will probably take the form of a split pipe, and in this case the water will recede when the Pump is stopped. A split pipe is sometimes difficult to locate. All pipes should be examined carefully as they are pulled up. It is advisable to replace a split pipe with a new one, but if no new one is available, the split may be repaired by cleaning the pipe thoroughly with a file, if necessary, over the whole length of the split, and binding stout galvanised wire tightly round the pipe, continuing beyond the end of the split and then soldering this wire to the pipe over the split.

**Cases Nos. 3 and 4** will be caused by a failing supply in bore or well. After Pump has been stopped for some time it has a body of water to start on, which has accumulated while it has not been working. When this accumulation has been exhausted and the supply coming into the bore or well is not sufficient to fill the Pump at each stroke, then part air and part water is pumped, and it is the bubble of air rushing up the pipe under pressure which causes the splashing of water over the Spill Piece. The failure of the supply can be definitely proved by pouring a plentiful supply of water into the bore or well while the Pump is working and immediate alteration will be seen in the amount of the discharge.

**Case No. 5** will be caused by either a Suction Pipe being too long or too small in diameter, or the Suction Pipe being partially choked. What happens is that the water does not flow into the Pump Barrel behind the Plunger when it is on the up stroke sufficiently fast to fill the space left vacant by it, which tends to cause a partial vacuum below the Plunger. On the commencement of the down stroke of the plunger the whole of the water above the plunger falls with it through the partial vacuum until the Plunger meets the water imprisoned in the bottom of the Barrel. Water is practically incompressible and the resounding knock which occurs is water hammer, set up by the sudden arresting of the long column of water which is above the Plunger. This water hammer is very often mistaken for a knock in the Windmill itself. Certainly it can sound as if it is. The knock will not do as much damage as might be expected, but will probably cause split Pipes or split Pump barrel ultimately. To avoid any possibility of this happening a sound rule is to have not more than 18ft. of Suction Pipe below the Pump and see that it is at least half the diameter of the Pump, and see that the Strainer and Foot Valve, if any, give a waterway the full size of the pipe.

**Case No. 6** will be caused either by leaking Valves or leaking Delivery Pipes See No. 2 (b) and (c).

**Case No. 7:** This is not unusual in old Pumps. It is caused by scale and rust from the inside of the Pipes falling down and holding up the Plunger Valve. See No. 1 (c) on Page 23.

## Care of Pumps

The following notes will be of assistance to those not familiar with pump repairs:

(1) When renewing Buckets several points need care:—

- Soak the Leather Buckets in water to allow them to swell before fitting, and, when fitted to the Plunger, see that it works freely in the Cylinder.
- When cutting out the centre of the Buckets be careful that the hole is concentric with the outside of the Bucket. To do this, place the Cage inside the Bucket so that it is even all round and mark the circle of the inside of the Cage with a pencil.
- When assembling or disassembling the Pump do not use pipe tongs on the Cylinder—one on each of the hexagon ends will do.
- To unscrew the plunger place the cage in a vice so two of the webs sit against one jaw and two against the other jaw. Allow the cage to sit loosely between the jaws and **do not use any pressure**, or the cage may be damaged. If a vice is not available, hold the cage by inserting a bar through it. The plunger follower may be unscrewed by holding a short piece of bar against the lugs provided and tapping it with a hammer.
- When reassembling, screw everything up tight.

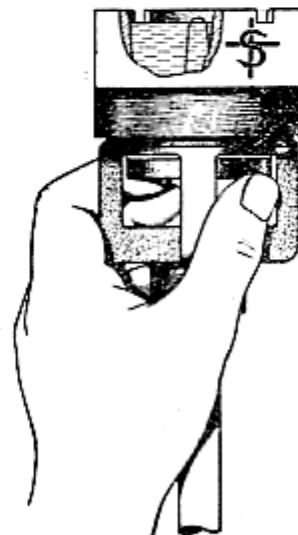

Testing Valves for Leaks

- (2) Leaking Valves are not difficult to locate; test the bottom one by filling the Barrel and watching underneath the Valve for leakage. The Plunger Valve can be tested by inverting the Plunger and holding the Valve against its seat with the fingers. (See illustration.)

Fill the inside of the Plunger with water and watch for leakage between the Valve and its seat.

If the Valve is held up it may be caused by an obstacle between the Valve and its seat or by the Valve itself jamming against its Cage. When testing Valves, it is well to see if it is possible for the Valves to jam by trying to make them do so by hand.

## Instructions for Fitting Southern Cross "IZ" Mills on to Older Pattern Southern Cross Towers, or Any Other Make of Tower.

### GENERAL INSTRUCTIONS.

The most important point to remember is that after the Stub Tower has been bolted in position on the existing Tower it must be vertical. Check it with a spirit level in three positions round the Mast Pipe.

On all Towers which have adjustable Braces strained at the top with Eye Bolts in the bottom Tower Casting, the Casting must be left in position to carry these Braces.

The Pump Rod Guide, No. 119, must be fitted at the most convenient point on the existing Tower so that it will function as intended, and as shown in the instructions for erecting an "IZ" Pattern Mill on Page 17 of these erecting instructions.

If the existing Tower is one with four legs it is necessary to order a Southern Cross "IZ" Pattern Mill with a Four-Post Stub Tower.

For Southern Cross Towers, instructions are set out below for each possible combination. They show how to proceed to erect an "IZ" Pattern Mill on each size of the older pattern Southern Cross Mill Towers.

For other makes of Towers the same principles apply, but it is not possible to set out the exact details. Both the erector and the owner of the Windmill are asked to see that a thoroughly neat and workmanlike job is made of putting the new Windmill on the old Tower.

We have seen many cases where a very poor and untidy job has been made of this work; such as leaving pieces off, leaving bolts out, using wire, and so forth. Hence this caution.

Check the size Pump and the height the water is lifted, with the pumping table on Page 29, and be sure that the Mill is not overloaded.

## Index of Instructions for Fitting Southern Cross "IZ" Pattern Mills on Old Style Southern Cross Towers.

Refer to paragraphs 1 to 5, Pages 26 and 27.

### 6ft. "IZ" Mill on 7ft., 1903, and 7ft., 1911, 60deg., Towers.

Stub Tower inside Tower Legs. Refer to paragraph 1.

60deg. Legs will have to be bent out to suit 90deg. Stub Legs. Wood Guide, No. 119, not used. Old Mill Guide used instead. Wood Pump Rod cut down to go through old Turntable. Refer to paragraph 3.

### 6ft. "IZ" Mill on 7ft., 1911, 90deg., Tower.

Stub Tower inside Tower Legs. Refer to paragraph 1.

Wood Guide, No. 119, not used. Old Mill Guide used instead. Wood Pump Rod cut down to go through old Turntable. Refer to paragraph 3.

### 6ft "IZ" Mill on 7ft. "F" Tower.

Stub Tower outside Tower Legs. Refer to paragraph 2.

Wood Guide, No. 119, bolted on top of old Turntable. Refer to paragraph 5.

### 6ft. "IZ" Mill on 6ft. "Z1" Tower.

Stub Tower outside Tower Legs. Refer to Paragraph 2.

### 6ft. and 8ft. "IZ" Mills on 8ft., 1903, and 8ft., 1911, 60deg., Towers.

Stub Tower inside Tower Legs. Refer to paragraph 1.

60deg. Legs will have to be bent out to suit 90deg. Stub Legs. Wood Guide, No. 119, bolted to first Girt as set out on Page 17 and paragraph 1.

### 6ft. and 8ft. "IZ" Mills on 8ft., 1911, 90deg., and 8ft. No. 1 Standard Towers.

Stub Tower inside Tower Legs. Refer to paragraph 1.

Wood Guide, No. 119, bolted to first Girt as set out on Page 17 and paragraph 1.

### 6ft. and 8ft. "IZ" Mills on 8ft. "G" Tower.

Stub Tower outside Tower Legs. Refer to paragraph 2.

Wood Guide, No. 119, bolted on top of old Turntable. Refer to paragraph 5.

### 8ft. "IZ" Mill on 10ft., 1903, and 10ft., 1911, 60deg., Towers.

Stub Tower inside Tower Legs. Refer to paragraph 1.

60 deg. Legs will have to be bent to suit 90deg. Stub Legs. Wood Guide, No. 119, bolted to first Girt as set out on Page 17 and paragraph 1.

### 8ft. "IZ" Mill on 10ft., 1911, 90deg., and 10ft. No. 1 Standard Tower.

Stub Tower inside Tower Legs. Refer to paragraph 1.

Wood Guide, No. 119, bolted to first Girt as set out on Page 17.

**8ft. "IZ" Mill on 10ft. "G" Tower.**

Stub Tower outside Tower Legs. Refer to paragraph 2.  
Wood Guide, No. 119, bolted to top of old Turntable. Refer to paragraph 5.

**8ft. "IZ" Mill on 8ft. "Z1" Tower.**

Stub Tower outside Tower Legs. Refer to Paragraph 2.

**10ft. "IZ" Mill on 10ft., 1903, and 10ft., 1911, 60deg., Towers.**

Stub Tower inside Tower Legs. Refer to paragraph 1.  
60deg. Legs will have to be bent out to suit 90deg. Stub Legs. Wood Guide, No. 119, not used. Old Mill Guide used instead. Refer to paragraph 8.

**10ft. "IZ" Mill on 10ft., 1911, 90deg., Tower.**

Stub Tower outside Tower Legs. Refer to paragraph 2.  
Wood Guide, No. 119, bolted to first Girt as set out on Page 17. Wood Pump Rod cut down to clear Turntable. Refer to paragraphs 3 and 4.

**10ft. "IZ" Mill on 10ft. "G" Tower.**

Stub Tower outside Tower Legs. Refer to paragraph 2.  
Wood Guide, No. 119, bolted to top of old Turntable. Refer to paragraph 5.

**10ft. "IZ" Mill on 10ft. No. 1 Tower.**

Stub Tower outside Tower Legs. Refer to paragraph 2.  
Wood Guide, No. 119, bolted to first Girt as set out on Page 17.

**10ft. "IZ" Mill on 10ft. "Z2" Tower.**

Stub Tower inside Tower Legs. Refer to Paragraph 1.

**10ft. and 12ft. "IZ" Mills on 12ft., 1903, and 12ft., 1911, 60 deg.; 14ft., 1903, and 14ft., 1911, 60deg., Towers.**

Stub Tower inside Tower Legs. Refer to paragraph 1.  
60deg. Tower Legs will have to be bent out to suit 90deg. Stub Legs. Wood Guide, No. 119, bolted to first convenient Girt as set out on Page 17. Corners of Wood Rod cut away to clear Turntable. Refer to paragraphs 3 and 4.

**10ft. and 12ft. "IZ" Mills on 12ft., 1911, 90deg.; 12ft. "G" and 12ft. No. 1 Towers.**

Stub Tower outside Tower Legs. Refer to paragraph 2.  
Wood Guide, No. 119, bolted to first convenient Girt, as set out on Page 17.

**12ft. "IZ" Mill on 12ft. "Z2" Tower.**

Stub Tower inside Tower Legs. Refer to Paragraph 1.  
To prevent fans from fouling on the platform, it is necessary to lower the platform by replacing original platform brackets with longer brackets, as supplied with 10ft. and 12ft. "FA" Pattern Towers.

**14ft. "IZ" Mills on 14ft., 1903; 14ft. 1911, 60deg.; 16ft., 1903; 16ft., 1911, 60deg., Towers.**

Stub Tower inside Tower Legs. Refer to paragraph 1.  
60deg. Tower Legs will have to be bent out to suit 90deg. Stub Legs. Wood Guide, No. 119, bolted to the first convenient Girt, as set out on Page 17. Corners of Wood Rod cut away to clear Turntable. Refer to paragraphs 3 and 4.  
It may be necessary to drill holes in Girts to attach Wood Pump Rod Guide.

**14ft. "IZ" Mills on 14ft., 1911, 90deg.; 16ft., 1911, 90deg.; 14ft. and 16ft. "A" Pattern Towers.**

Stub Tower inside Tower Legs. Refer to paragraph 1.  
Wood Guide, No. 119, bolted to first convenient Girt, as set out on Page 17.  
It may be necessary to drill holes in Girts to attach Wood Pump Rod Guide.

**14ft. "IZ" Mill on 14ft. "Z2" Tower.**

Stub Tower outside Tower Legs. Refer to Paragraph 2.

# Instructions for Fitting Southern Cross "IZ" Pattern Mills on Old Style Southern Cross Towers.

Refer to Index on Page 25.

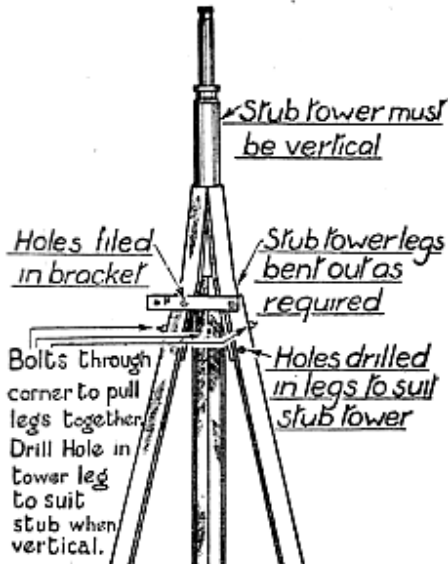

Fitting Stub Tower Inside Tower Legs

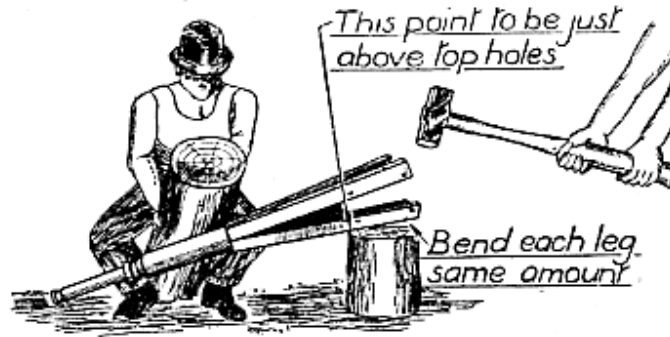

Bending Stub Tower Legs

**Paragraph 1.**

When the Stub is fitted inside the Tower (see illustration, "Fitting Stub Tower Inside Tower Legs," the Stub Tower Legs are bent out to suit. (See illustration, "Bending Stub Tower Legs.") Be careful to bend each Leg the same amount. The Tower Legs are sprung in.

The Girts and Braces on the first 10ft. section of the Tower will have to be removed to spring the Legs in.

In some Towers the bending of the Stub and Tower Legs will not be necessary. In these cases, after the Legs and Stub have been fitted somewhere near to shape, set the Stub so that it is vertical and then drill, using a chain drilling attachment, a 7/16in. or 9/16in. hole from the inside through the corner of each Tower Leg and Stub Leg, as shown in the illustration, "Fitting Stub Tower Inside Tower Legs."

As each Leg is drilled, fit a suitable Bolt and Spring Washer from the old Mill so that it holds the Leg firmly.

**It is very important that Spring Washers be fitted for 12ft. and 14ft. "IZ" Mills.**

Then check and see that the Stub is plumb before each hole is drilled.

When all the Legs have been drilled and fitted with Bolts and Spring Washers, commence to tighten each nut up a turn at a time, and at the same time hammering the Tower Leg and Stub Leg to set them. This is continued until the Legs fit snugly together and the Stub is plumb.

Now, using the holes in the Stub Legs as guides, drill the four holes in each leg and fit Bolts and Spring Washers. The holes will be drilled from the outside, but it is easy to judge where to drill to meet the holes in the Stub Legs.

Now fit old Braces and Girts to Tower, cutting and redrilling where necessary.

The Reefing Rocker, No. 99, with Reefing Rocker Brackets, is attached to the top holes of the joint.

See illustration, "Fitting Stub Tower Inside Tower Legs."

The holes in the Reefing Rocker Brackets will have to be filed to fit in the bolts.

Now replace the Girts and Braces.

**Paragraph 2.**

**Before fitting the Stub Tower, file off the sharp corners on the outside of the Tower Legs far enough to allow the Legs of the Stub Tower to fit outside the Tower Legs without riding on the sharp corners.**

When the Stub is fitted outside the Tower (see illustration, "Fitting Stub Tower Outside Tower Legs") the Tower Legs may have to be bent out to suit. Try the new Stub Tower on to see if the top of the Tower Legs have to be bent. If they have, proceed as follows:

Remove the Girts and Braces and Legs from the top of the Tower and reassemble them on the ground.

Then bend each Leg until the Stub fits properly by trial. The method of bending is shown in the illustration, "Bending Stub Tower Legs." This shows how to bend Stub Legs. The Tower Legs are bent in a similar manner.

After the Legs have been bent correctly, replace Tower Legs and Braces, etc., in position to Tower and tighten up securely.

Now put Stub in position on top of the Tower, and clamp each Stub Leg to its corresponding Tower Leg. Each Leg must be firmly clamped so that it fits properly the whole length.

Refer to instructions for drilling and fitting as set out in paragraph 1. **and be sure that Spring Washers are fitted to bolts holding on the Stub Tower.**

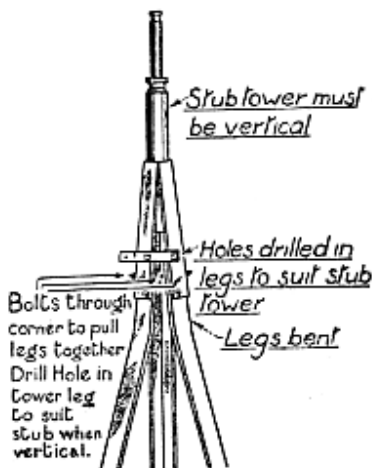

Fitting Stub Tower Outside Tower Legs

Now proceed to assemble the Mill Engine as set out on Page 9, but first it is necessary to put Reefing Rocker, No. 99, Reefing Rocker Brackets, No. 91, and Reefing Collar, No. 20, in position on the Stub Tower; they are attached to the top joint holes. Refer to illustration, "The Mill Engine," Page 10.

**Paragraph 3.**

1903 and 1911 Towers are braced with Flat Braces strained at the top, and it is necessary to leave the old bottom Tower Casting in position to take the straining eye bolts for the Braces.

The Wood Pump Rod on your new Mill will have to be cut down to go through the hole in the bottom Tower Casting.

This makes it impossible to use the new Guide, No. 119, in position above the casting. (See "Illustration for Paragraph 3.")

As a guide is absolutely necessary, one of the following methods will have to be used:—

**1903 Towers—**

Using the old Guide instead of the new one, cut the Flat Bar Pump Rods about 6in. above the swivel and then two holes are drilled in each bar.

Bolt the Wood Pump Rod to the Flat Bar by means of bolts through holes in the Flat Bar as in "A," "Illustration for Paragraph 3."

**1911 Towers—**

Using the old Cast Iron Guide instead of the new one, remove the old Pump Rod Swivel from the top of the Flat Bar Pump Rods.

Attach the Wood Rod to the Flat Bar, as in "B," "Illustration for Paragraph 3."

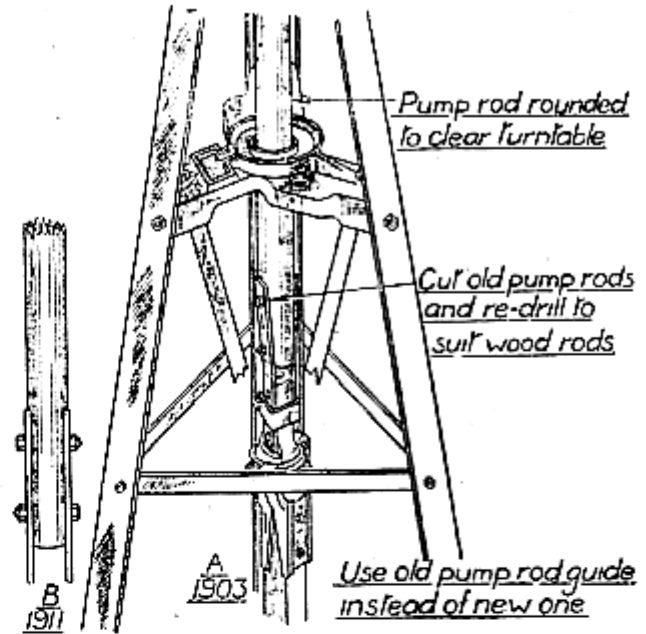

Illustration for Paragraph 3.

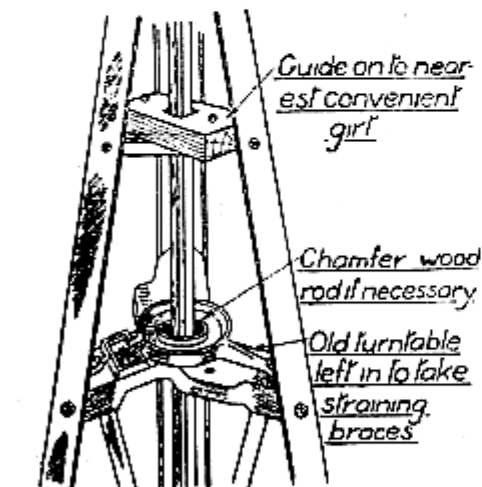

Illustration for Paragraph 4.

**Paragraph 4.**

1903 and 1911 Towers are braced with Flat Braces strained at the top, and it is necessary to leave the old bottom Tower Casting in position to take the straining Eye Bolts for the Braces.

The new Wood Pump Rod will go through the hole in the old Turntable with only a slight chamfering on the corners. (See "Illustration for Paragraph 4.")

The Wood Guide for the Pump Rod is put on the First Girt in a similar manner as set out on Page 17.

It will be necessary to cut the Guide to clear the Tower Leg.

**Paragraph 5.**

When the Wood Guide, No. 119, is being fitted to 8ft., 10ft., and 12ft. "G" Towers, it will be necessary to bolt the Guide to the old Turntable. This is left in position. (See "Illustration for Paragraph 5.")

Extra holes are bored in the Wood Guide, No. 119, and the two Hook Bolts supplied hooked under the Casting.

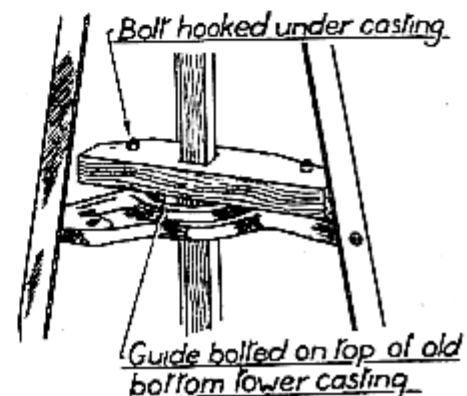

Illustration for Paragraph 5.



## Instructions For Fitting Southern Cross Windmills on Towers of Other Makes.

The Important Points are:—

1. To see that the Stub Tower is perfectly vertical.
2. To see that all necessary Braces and Girts are in the Tower, and all bolts tightened up so that it is a rigid structure.
3. To see that the Guide is fitted.
4. To see that Spring Washers are used when bolting the Stub Tower to the Tower Legs.

The Southern Cross Stub will fit either inside or outside the Legs of the existing Tower. This is determined by trial. It may be necessary to bend the Legs of the Stub outwards according to the instructions given in Paragraph 1, or it may be necessary to bend the Tower Legs outwards according to the instructions given in Paragraph 2.

## PUMPING CAPACITIES OF "IZ" PATTERN WINDMILLS

The right combination of Windmill and Pump is always one which will allow the mill to work easily in light winds. The pumping table below shows the average daily supply which you can expect with each combination of windmill and pump up to the depths given. This table applies to most districts in Australia providing that the windmill is erected on a sufficiently high tower in a good open site where the wind can reach the windwheel freely.

In some districts, however, the wind is not strong, and in these positions a larger size of windmill is required. A larger windmill than would normally be used would also be required where the wind does not blow for many hours a day on the average.

Size Mill		DIAMETER OF PUMP CYLINDER													
		1¾in.	2in.	2¼in.	2½in.	2¾in.	3in.	3¼in.	3½in.	4in.	4¼in.	4½in.	5in.	6in.	6in.
6ft. "IZ"	Total Lift in Feet	73	60	51	43	37	32	27	24	19	17	15	12		
	Avg. Galls. per day	795	1040	1320	1630	1970	2345	2750	3190	4165	4705	5275	6510		
8ft. "IZ"	Total Lift in Feet	132	109	92	77	66	57	50	44	34	31	28	23	16	
	Avg. Galls. per day	875	1145	1450	1790	2165	2575	3025	3505	4580	5170	5795	7155	10305	
10ft. "IZ"	Total Lift in Feet	236	197	166	141	121	105	92	81	64	57	51	42	30	
	Avg. Galls. per day	855	1115	1415	1745	2110	2515	2950	3420	4465	5040	5655	6980	10450	
12ft. "IZ"	Total Lift in Feet	315	263	222	189	162	140	123	108	85	76	68	56	40	23
	Avg. Galls. per day	925	1285	1530	1885	2285	2720	3190	3700	4830	5455	6115	7550	10370	19325
14ft. "IZ"	Total Lift in Feet	443	370	312	265	228	197	172	151	119	107	96	79	56	32
	Avg. Galls. per day	790	1035	1316	1620	1955	2315	2730	3165	4125	4670	5235	6470	9310	16540





# Nº2

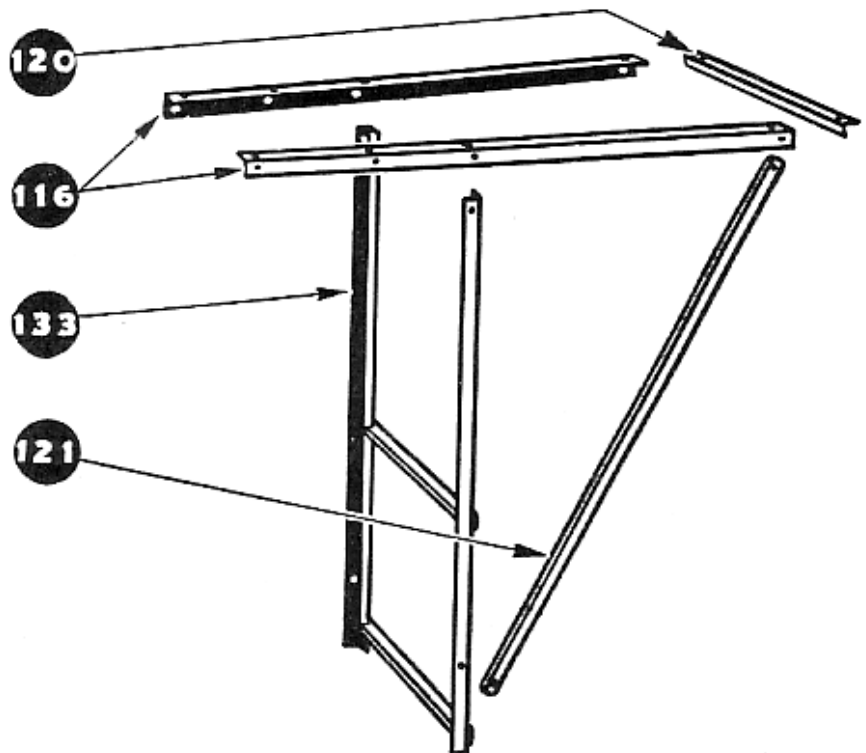
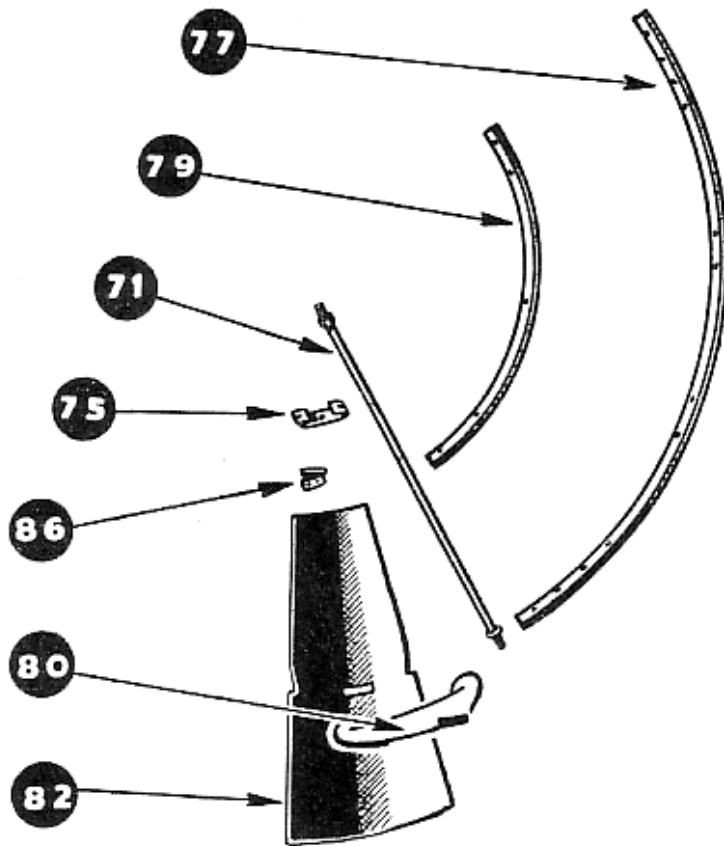
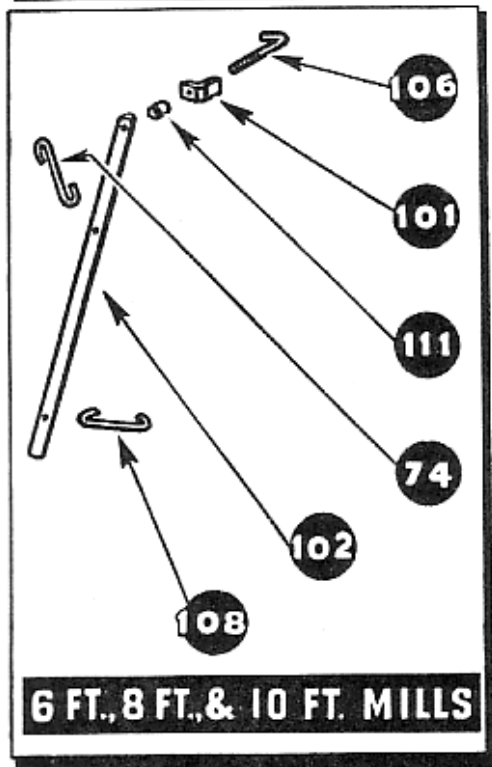
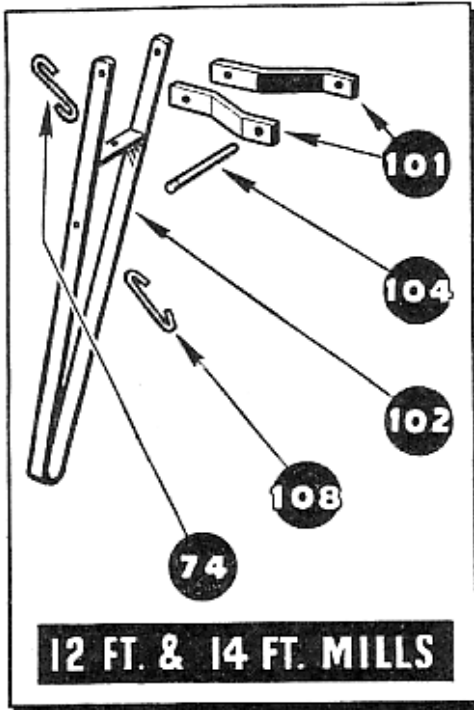

# PARTS LIST—Southern Cross "IZ" Pattern Windmills

THE MILLS ARE NUMBERED ON TOP OF THE MAIN BEARING, JUST BEHIND THE WHEEL HUB.  
THE NUMBERS MUST ALWAYS BE QUOTED WHEN MAKING ANY REFERENCE TO THE MILL.

No. Per Mill	6ft.	8ft.	10ft.	12ft.	14ft.	Name of Part.
	IZ-A	IZ-B	IZ-C	IZ-D	IZ-E	
1	IZ-A 1	IZ-B 1	IZ-C 1	IZ-D 1	IZ-E 1	Gearbox.
2	IZ-A 3	IZ-B 3	IZ-C 3	IZ-D 3	IZ-E 3	Gearwheel.
2	IZ-A 5C	IZ-B 5C	IZ-C 5C	IZ-D 5C	IZ-E 5C	Pinion.
1	IZ-A 6	IZ-B 6	IZ-C 6	IZ-D 6	IZ-E 6	Oil Scraper.
1	IZ-A 7	IZ-B 7	IZ-C 7	IZ-D 7	IZ-E 7	Gearwheel Shaft.
1	IZ-A 8B	IZ-B 8B	IZ-C 8	IZ-D 8	IZ-E 8	Wheel Hub.
2	Z-A 9	Z-B 9	Z-C 9	Z-D 9	Z-E 9	Connecting Rod.
2	Z-A 11	Z-B 11	Z-C 11	Z-D 11	Z-E 11	Connecting Rod Retaining Plug.
1	IZ-A 13	IZ-B 13	IZ-C 13	IZ-D 13	IZ-E 13	Main Bearing
1	IZ-A 14	IZ-B 14	IZ-C 14	IZ-D 14	IZ-E 14	Pinion Bearing
1	IZ-A 15B	IZ-B 15B	IZ-C 15B	IZ-D 15B	IZ-E 15B	Gearwheel Bearing
1	Z-A 16B	Z-B 16	Z-C 16	Z-D 16	Z-E 16	Crosshead.
1	Z-A 17B	Z-B 17	Z-C 17	Z-D 17	Z-E 17	Crosshead Roller.
1	IZ-A 19B	IZ-B 19B	IZ-C 19	IZ-D 19	IZ-E 19	Vane Toggle Casting
1	Z-A 20B	Z-B 20	Z-C 20	Z-D 20	Z-E 20	Reefing Collar.
1	Z-A 22	Z-A 22	Z-A 22	Z-D 22	Z-E 22	Helmet Wing Nut.
1	IZ-A 23	IZ-A 23	IZ-C 23	IZ-D 23	IZ-E 23	Main Bearing Locking Screw
1	Z-A 25	Z-B 25	Z-C 25	Z-D 25	Z-E 25	Turntable Pivot Tube Circlip.
2	†A-S 27					Mast Pipe Clamp Block
1			Z-C 50	Z-D 50	Z-E 50	Wheel Hub Key
1	IZ-A 51B	IZ-B 51B	IZ-C 51	IZ-D 51	IZ-E 51	Main Shaft.
1	Z-A 54	Z-B 54	Z-C 54	Z-D 54	Z-E 54	Pump Rod Pin.
1	Z-A 55	Z-B 55	Z-C 55	Z-D 55	Z-E 55	Brass Stud for Helmet.
1	Z-A 56	Z-B 56	Z-C 56	Z-D 56	Z-E 56	Crosshead Pin.
1	Z-A 58	Z-B 58	Z-C 58	Z-D 58	Z-E 58	Guide Bars.
1	IZ-A 59	Z-B 59	IZ-C 59	IZ-D 59	IZ-E 59	Oil Collector Peg.
2	Z-A 63	Z-B 63	Z-C 63	Z-D 63	Z-E 63	Guide Bars Fixing Pin.
2	Z-A 65C	Z-B 65B	Z-C 65B	Z-D 65B	Z-E 65B	Crosshead Oil Ring.
3	Z-A 66	Z-B 66	Z-C 66	Z-D 66	Z-E 66	Turntable Washers.
4	Z-A 68	Z-A 68	Z-C 68	Z-D 68	Z-E 68	Rivet for Reefing Rocker.
2	Z-A 69	Z-A 69	Z-C 69	Z-D 69	Z-E 69	Rivet for Reefing Collar.
1	IZ-A 70	IZ-B 70	IZ-C 70	IZ-D 70	IZ-E 70	Main Shaft Oiling Spring.
12	IZ-A 71	IZ-B 71	IZ-C 71	IZ-D 71	IZ-E 71 (16 off)	Wheel Arm
2	Z-A 74	Z-A 74	Z-C 74	Z-D 74	Z-E 74	Hook for Reefing Rocker.
6	IZ-A 75	IZ-B 75	IZ-C 75	IZ-D 75	IZ-E 75 (8 off)	Inner Ring Bracket.
6	Z-A 77	Z-B 77	Z-C 77	Z-D 77	Z-E 77 (8 off)	Outer Ring.
6	Z-A 79	Z-B 79	Z-C 79	Z-D 79	Z-E 79 (8 off)	Inner Ring.
18	IZ-A 80	IZ-B 80	IZ-C 80	IZ-D 80	IZ-E 80 (24 off)	Outer Fan Bracket.
1	IZ-A 81	IZ-B 81	IZ-C 81	IZ-D 81	IZ-E 81	Reefing Rocker Assembly—3 Post (not illus.).
18	IZ-A 82	IZ-B 82	IZ-C 82	IZ-D 82	IZ-E 82 (24 off)	Fans.
1	IZ-A 84	IZ-B 84	IZ-C 84	IZ-D 84	IZ-E 84	Vane Hinge Pin Washer
18	Z-A 86	Z-B 86	Z-C 86	Z-D 86	Z-E 86 (24 off)	Inner Fan Bracket
1	IZ-A 87	IZ-B 87	IZ-C 87	IZ-D 87	IZ-E 87	Vane Hinge Pin.
1	IZ-A 88	IZ-B 88	IZ-C 88	IZ-D 88B	IZ-E 88B	Toggle Pin.
1	IZ-A 89	IZ-B 89	IZ-C 89	IZ-D 89	IZ-E 89B	Vane Stay.
2	Z-A 91C	Z-A 91C	Z-C 91B	Z-D 91B	Z-E 91B	Reefing Rocker Bracket—3 Post.
1	Z-A 92	Z-B 92	Z-C 92	Z-D 92	Z-E 92	Gearwheel Bearing Clamp.
1	IZ-A 95	IZ-B 95	IZ-C 95	IZ-D 95	IZ-E 95	Stub Tower—3 Post
1	Z-A 97B	Z-A 97B	Z-C 97B	Z-D 97B	Z-E 97B	Stub Tower Girt—3 Post.
1	IZ-A 98B	IZ-B 98B	IZ-C 98	IZ-D 98	IZ-E 98	Toggle Rod.

† These parts supplied only when mounting 6ft. "IZ" Mills on Wood Posts.

PARTS LIST—(Continued).

No. Per Mill	6ft. IZ-A	8ft. IZ-B	10ft. IZ-C	12ft. IZ-D	14ft. IZ-E	Name of Part.
1	Z-A 99C	Z-B 99B	Z-C 99B	IZ-D 99	IZ-E 99	Reefing Rocker—3 Post.
2	Z-A100C	Z-B100B	Z-C100B	IZ-D100	Z-E100B	Link to Reefing Collar—3 Post
1	Z-A101	Z-A101	Z-A101	Z-D101B (2 off)	Z-D101B (2 off)	Reefing Handle Clip.
1	IZ-A102	IZ-B102	IZ-C102	Z-D102	Z-D102	Reefing Handle.
1	Z-A103	Z-B103	Z-C103	Z-D103	Z-D103	Pump Rod.
1	—	—	—	Z-D104	Z-D104	Reefing Handle Pin.
1	Z-A106	Z-A106	Z-A106	—	—	Reefing Handle Hook Bolt.
1	Z-A108B	Z-A108B	Z-A108B	Z-A108B	Z-A108B	Reefing Handle Catch.
1	—	—	—	—	IZ-E110	Vane Stay Spacer (not illus.).
1	Z-A111	Z-A111	Z-A111	—	—	Reefing Handle Collar.
2	—	—	Z-C116	Z-C116	Z-C116	Ladder Bracket.
1	IZ-A119	IZ-A119	IZ-C119	IZ-C119	IZ-C119	Wood Guide for Pump Rod (3 Post)
1	—	—	Z-C120	Z-C120	Z-C120	Ladder Bracket Stay.
2	—	—	Z-C121	Z-C121	Z-C121	Ladder Stay.
1	Z-A124B	Z-B124B	IZ-C124	IZ-D124	IZ-D124	Helmet.
1	IZ-A127	IZ-B127	IZ-C127	IZ-D127	IZ-D127	Oil Ring Guide—Right Hand.
1	IZ-A128	IZ-B128	IZ-C128	IZ-D128	IZ-D128	Oil Ring Guide—Left Hand.
1	IZ-A132	IZ-B132	IZ-C132	IZ-D132	IZ-E132	Vane Triangle.
1	—	—	Z-C133	Z-C133	Z-C133	Rotating Ladder.
1	IZ-A135	IZ-A135	IZ-C135	IZ-C135	IZ-C135	Wood Guide for Pump Rod—4 Post.
2	IZ-A144	IZ-B144	IZ-C144	IZ-D144	IZ-E144	Vane Sheet
1	IZ-A147	IZ-B147	IZ-C147	IZ-D147	IZ-E147	Stub Tower—4 Post.
2	Z-A148B	Z-A148B	Z-C148B	Z-D148B	Z-D148B	Reefing Rocker Bracket—4 Post.
2	Z-A149B	Z-A149B	Z-C149B	Z-D149B	Z-D149B	Stub Tower Girt—4 Post.
1	Z-A161	Z-A161	Z-A161	Z-D161	Z-D161	Guard for Guide Bars.
1	Z-A166B	Z-B166B	Z-C166B	IZ-D166	IZ-E166	Reefing Rocker—4 Post.
2	Z-A167B	Z-B167B	Z-C167B	IZ-D167	Z-E167B	Link to Reefing Collar—4 Post.
1	IZ-A168	IZ-A168	IZ-C168	IZ-C168	IZ-C168	Wood Pump Rod—4ft. length.
1	IZ-A169	IZ-B169	IZ-C169	IZ-D169	IZ-E169	Reefing Rocker Assembly—4 Post (not illus.).
1	†IZ-A170	—	—	—	—	Mast Pipe
1	†IZ-A171	—	—	—	—	Reefing Rocker Bracket
1	†IZ-A172	—	—	—	—	Wood Pump Rod Guide
2	†IZ-A173	—	—	—	—	Mast Pipe U Bolt
1	IZ-A178	IZ-B178	IZ-C178	IZ-D178	IZ-E178	Inner Vane Rib
1	—	IZ-B179	IZ-C179	IZ-D179	IZ-E179	Intermediate Vane Rib—Short
1	IZ-A180	IZ-B180	IZ-C180	IZ-D180	IZ-E180	Outer Vane Rib
1	—	—	—	—	IZ-E181	Intermediate Vane Rib—Long
4	3/8in x 3/8in B.S.F.	3/8in x 3/8in B.S.F.	M12 x 12	M16 x 16	M16 x 16	Pinion Locking Screw

† These parts supplied only when mounting 6ft. "IZ" Mills on Wood Posts.