

20-9-72

Instruction Manual *for..*

SOUTHERN CROSS

GEARED SELF-OILING

POWER PUMPS

FIGS. 2550 & 3187

MANUFACTURED IN AUSTRALIA

BY

TOOWOOMBA FOUNDRY PTY. LTD.

AND MARKETED BY

SOUTHERN CROSS MACHINERY COMPANIES



**Read this Instruction Manual carefully
before Installing or Operating your Pump.**

★ ★ ★

HANG THIS INSTRUCTION MANUAL IN A HANDY PLACE
NEAR THE PUMP FOR FUTURE REFERENCE.

★ ★ ★

FOREWORD . . .

Southern Cross Power Pumps are soundly engineered and carefully built. Rigid inspection of parts during manufacture ensures that all pumps are of the same high quality.

The instructions in this manual have been specially prepared to enable each user of a Southern Cross Power Pump to obtain the best from his pump. A little extra attention to the installation of the pump, piping, etc. will be amply repaid in years of trouble-free service.

Fig. 3187

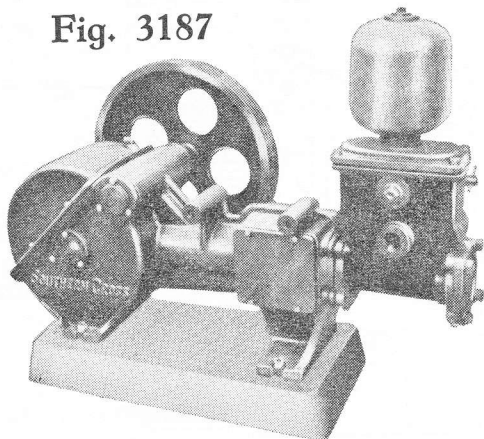
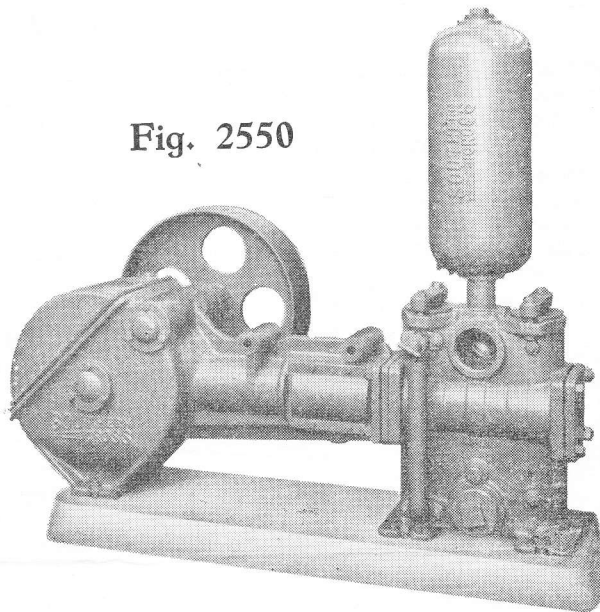

Fig. 2550



Southern Cross Fig. 3187 Geared Self-Oiling Power Pump incorporates the Mark AL-E Drive Gear, which has a 5in. stroke, combined with one of the following sizes of pumps:—Mark KH-E, 2½in. bore; Mark KH-F, 3in. bore; Mark KH-G, 3½in. bore; Mark KH-H, 4in. bore, and Mark KH-J, 5in. bore.

Southern Cross Fig. 2550 Geared Self-Oiling Power Pump incorporates the Mark AL-G Drive Gear, which has a 6in. stroke, combined with one of the following sizes of pumps:—Mark AN-I, 4in. bore; Mark AN-K, 5in. bore; and Mark AN-L, 6in. bore.

INSTALLATION

Assembling Pump

Some parts are removed from the pump for ease of packing and have to be fitted as follows:

Fig. 3187:

- (a) Remove air chamber from bottom of crate and air chamber rubber washers from hessian bag. Place washers in position and bolt air chamber to top of pump.
- (b) Screw air valve into side of suction pipe boss.

Fig. 2550:

- (a) Take the short air chamber to pump connecting pipe and screw it into the top of the pump. Then screw on the air chamber.
- (b) Fit washer to water cock valve assembly and screw into opening at top of water by-pass connection.
- (c) Screw air valve assembly into hole near right hand foot on by-pass side of pump.

Pump Drive

The pulley on the drive gear may be driven either clockwise or anti-clockwise.

Location

The pump should be located as near the source of supply as possible, but if sufficiently large suction piping is used the pump may be as much as 200 or 300 feet away. However, the suction lift from the surface of the water being pumped to the centre line of the pump must not be more than 18 feet, including friction. The pump should be placed so that it is accessible from all sides.

Foundation.

The pump should be placed upon a level and firm foundation. A concrete block with the foundation bolts set into it, makes a suitable foundation. (Refer general arrangement illustrations on Page 2.) A wooden template can be made to hold the bolts in position while the concrete is poured. The foundation bolts should be hung from the template so the tops will protrude 1½in. Fig. 3187, 2¼in. Fig. 2550, from the concrete after the template is removed.

When installing, put a level on the shaft of the drive gear to check that the pump and drive gear are level. If necessary, place shims under the feet to level the pump and drive gear.

Pipe Connections.

The suction and discharge may be taken from either side of the pump, or the suction from one side and the discharge from the other.

Piping.

Run all piping in as direct a line as possible; avoid all unnecessary turns; see that all joints and connections are tight, and if the pump lines are long, use a larger size pipe than that for which the pump is screwed. This will reduce friction and so reduce the load on the pump.

Where a long pipe line is used for either the suction or discharge, fit a Union or Flanges in the line close to the pump for ease of uncoupling if the pump ever has to be moved.

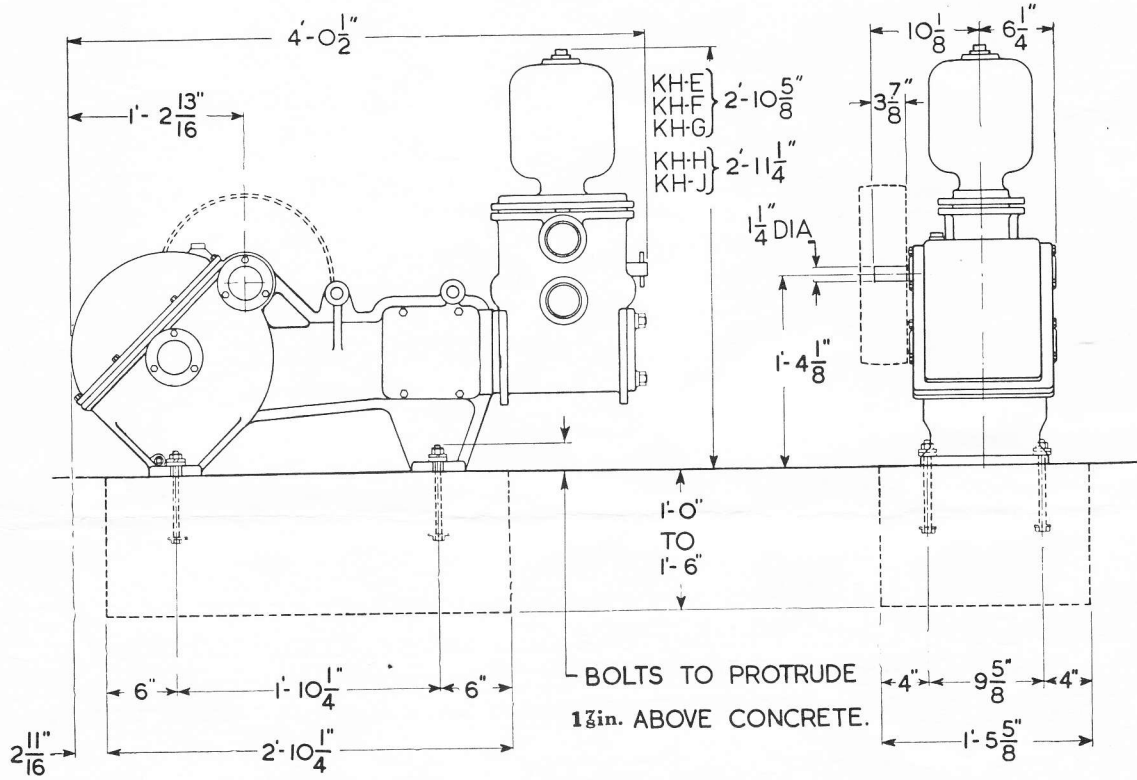

General Arrangement of Fig. 3187 Power Pump.

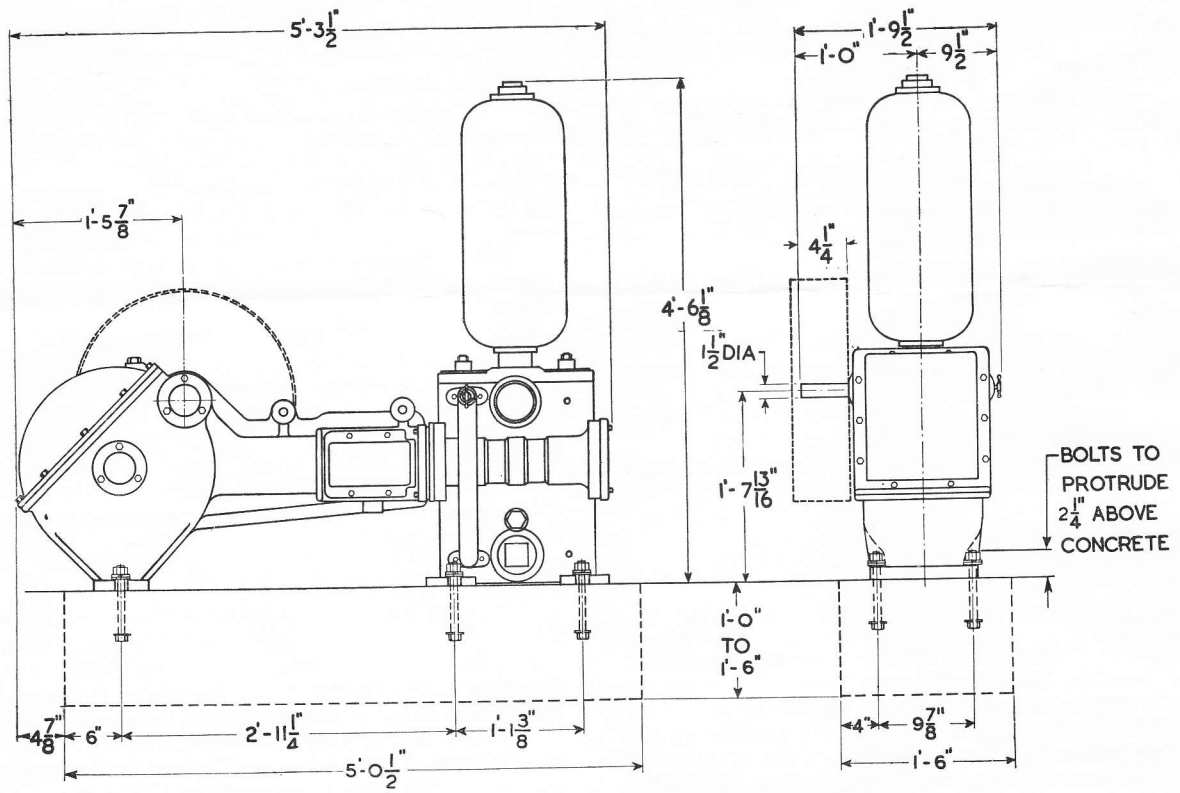

General Arrangement of Fig. 2550 Power Pump

Suction Pipe.

The suction pipe should in no case be smaller than the size of the suction screwing of the pump, and if very long, it should always be larger. In laying the suction pipe a uniform grade should be maintained throughout to avoid air pockets, and if possible the pipes should have a drop of not less than 6in. in every 100 feet length towards the source of supply.

Suction Chamber.

It is desirable that a suction chamber be fitted on all installations. The purpose of this suction chamber is to maintain a reservoir of water in the pump when stopped, preventing the buckets from drying out, thus giving positive pumping action immediately the power pump is started up. The suction chamber also provides an even flow of water on the suction side of the pump, thereby preventing water hammer.

For 2½in., 3in., 3½in., and 4in. Fig. 3187 Pumps, use Mark KM-D Suction Chamber, and for all other pumps use a Mark KM-E Suction Chamber.

The Suction Chamber is mounted vertically in the suction line. The side connection of the Suction Chamber is connected to the suction of the power pump and the suction pipe is connected into the bottom connection of the chamber.

Before starting the pump for the first time, it will be necessary to prime the pump. To do this, unscrew the Suction Chamber Priming Plug, and pour water into the chamber until the reservoir is full. Replace the Priming Plug.

FLOODED SUCTION: In an installation with a "flooded" suction, a "BY" Pattern air chamber is required in place of the "KM" Pattern suction chamber, on the suction pipe. A gate valve must be installed between the air chamber and the suction inlet, so that the air chamber may be drained. The gate valve must be fully opened before starting the pump, otherwise the pump may be damaged.

Priming.

For the initial run it may be necessary to prime the pump, but with a foot-valve fitted on the suction pipe it should not otherwise be required. If at any time the foot-valve should leak and make it necessary to prime the pump before starting, the foot-valve should be repaired immediately.

The Fig. 3187 Pump can be primed by pouring water in through the spare suction opening in the side of the pump or the top of the suction chamber. The Fig. 2550 Pump can be primed by opening the pump by-pass, removing the plug from the top of the air chamber, and pouring water into the top of the air chamber.

If a suction chamber is not fitted, the fitting of a tee with a plug in the top in the suction line close to the pump provides a simple means of priming. The plug is simply removed and the suction line filled with water.

Water By-Pass.

A Water By-pass is fitted to the pump so that the load on the driving machine can be reduced for starting. Each time before starting the pump, open the by-pass by screwing the handle of the valve in an anti-clockwise direction. While this valve is open some of the water being pumped is by-passed from the discharge. After the driving machine has got up speed, close the valve on the by-pass and the water will be passed through the discharge line.

Air Chamber.

An air chamber is fitted to the top of the pump to absorb pressure changes in the discharge line caused by variations in the flow, and also to help keep the water in the discharge line flowing smoothly.

The speed of a pump piston, during its travel in each direction, is not uniform, and on a pump not fitted with an air chamber the discharge flow would alternately surge and slow down. This surging effect can cause a severe shock which could cause "water hammer." With an air chamber fitted to the pump these shocks are absorbed by a cushion of air.

The air in the air chamber is gradually absorbed by the water, and the chamber loses its effectiveness, so it is important that the air valve (on this page) be left slightly open to feed air into the air chamber.

Foot Valve and Strainer.

A foot valve and strainer should always be fitted to the lower end of the suction pipe. The foot-valve keeps the suction pipe full of water when the pump is not being used, and ensures prompt starting on the next occasion. The strainer prevents foreign substances being drawn into the pump which could cause clogging of the pump valves.

Check Valves.

A check valve should be fitted at or near the pump in the discharge pipe to relieve the pump valves of the back pressure of water in the discharge pipe.

Also it will enable work to be carried out on the pump without the water draining back out of the discharge pipe. **WARNING:** Under no circumstances fit a Gate or Globe Valve in the discharge pipe instead of a check valve, as the pump would be damaged if it was ever started with the Gate Valve or Globe Valve closed.

RUNNING INSTRUCTIONS

Air Valve.

Due to pressure in the discharge line, the air in the air chamber is gradually absorbed by the water and unless a small quantity of air is constantly fed into the chamber, it will fill with water and become useless. To make sure that there is always air in the air chamber, **the air valve on the side of the pump should always be left slightly open** so that on each suction stroke a small amount of air will be drawn into the pump with the water to feed the air cushion in the air chamber.

For most installations an opening of $\frac{1}{8}$ to $\frac{1}{4}$ of a turn on the valve is sufficient. On pumps operating with a high suction lift, an excessive opening of the valve will allow too much air into the pump and prevent it from operating.

Draining Pump in Cold Conditions.

Severe damage may be caused to a pump by water in the pump body freezing in cold weather. Two drain plugs are located in the pump body to allow water to be drained from the pump. On Fig. 3187 power pumps, these plugs are at the bottom of the pump body, and on Fig. 2550 power pumps, the plugs are at the top and bottom of the pump body on the by-pass side of the pump.

MAINTENANCE

Gland.

The gland should be just tight enough to permit a small leakage from it when the pump is operating. This water will run from the drain hole at the pump end of the Drive Gear. If the leakage becomes excessive, remove the Gearbox Pump End Cover Plates and tighten the gland.

Do not tighten the gland too much as this will produce unnecessary friction and wear, and will also increase the power necessary to operate the pump.

Valves.

The Valves should be examined occasionally to see if they are seating properly. Foreign substances are likely to be drawn up through the suction pipe and become lodged between the valve and seat, causing leakage and a corresponding reduction in the capacity of the pump.

Lubrication.

From the oil reservoir in the base of the gearbox, oil is carried by the main gearwheel to the highest point, and by a system of channels is distributed to all moving parts and then returned again to the reservoir.

For very hot climates (where the temperature is consistently over 90° F.) **Southern Cross "HD" Pumphead and Drive Gear Oil—S.A.E. 140** should be used in these pumps; and, for cooler climates, **Southern Cross "HD" Pumphead and Drive Gear Oil—S.A.E. 90** should be used. In some cases it may be found necessary to change oil for winter and summer use.

The Gearbox should be drained and refilled with fresh oil every 500 hours.

Fill the Gearbox up to the mark on the dipstick. When checking the oil level, clean the dipstick and screw it back in before taking a reading.

The approximate quantity of oil required to fill the gearbox to the mark on the dipstick is: Fig. 3187 Power Pump, 7 pints; Fig. 2550 Power Pump, 1 gallon 3 pints.

To Replace Pump Buckets.

Remove the Gearbox Pump End Cover Plate. Loosen off setscrew in Crosshead and screw Plunger Rod out of Crosshead.

Loosen off the Splash Guard Setscrew and slip the Splash Guard off the Plunger Rod.

Remove the Inspection End Plate from the end of the Pump, loosen off the Packing Gland and the Plunger Rod, Plunger, Buckets, etc., can be removed.

Replace the Pump Buckets and reverse the above procedure to re-assemble Pump.

To Fit New Valve Seats

If it is ever necessary to fit new valve seats to the pump, proceed as follows:

Fig. 3187.

- (a) Remove the air vessel. Undo the discharge valve retaining clamp setscrews and locknuts and remove the clamps.
- (b) Lift out the discharge valve parts and the discharge valve seats.
- (c) Lift out the suction valve parts and the suction valve seats. It may be necessary to screw a long 5/16in. Whit. bolt into the top of the valve seat stem to assist in removing the seats.

Fig. 2550 Power Pump.

- (a) Undo the nuts holding the top and side clamps, remove the clamps, inspection port covers and gaskets.
- (b) Unscrew the valve guides and remove the springs, washers and rubbers.
- (c) It will be necessary to use a puller to remove the valve seats from the body.

To make a puller for the discharge seats, take a piece of 5/8in. steel bar and screw a short 5/8in. Whitworth thread on one end to screw into the valve seat. The other end should protrude above the top of the body and should have a long thread on it. A heavy piece of flat steel bar with a hole in the middle to take the 5/8in. bar will also be required. Screw the bar into the valve seat, place the piece of flat steel in position across the body and then screw on a nut. The discharge valve seat will be withdrawn as the nut is tightened down.

A similar procedure is used for the suction valve seats but a longer piece of bar will be required.

To fit the new valve seats, place them in position and bump them in carefully with the squared end of a piece of timber.

ELECTRIC MOTOR DRIVEN POWER PUMPING UNITS

Fitting Electric Motor

The electric motor base rails can be bolted on in several different ways — (1) Both horizontal flanges towards pulley. (2) Both horizontal flanges away from pulley. (3) Flanges in opposite directions. (4) Flanges

together. By trying the motor on the base rails, select the best arrangement for them.

Fit the vee pulley to the motor, sit the motor on the rails and line up the belt drive. Mark the bolt hole positions on the rail flanges, drill holes and then bolt on motor.

Parts List for Marks KH-E, KH-F, KH-G, KH-H, KH-I, KH-J, KH-K, AN-I, AN-J, AN-K, and AN-L Power Pumps

2 1/2 in. x 5 in. Mark KH-E		3 in. x 5 in. Mark KH-F		3 1/2 in. x 5 in. Mark KH-G		4 in. x 5 in. Mark KH-H		5 in. x 5 in. Mark KH-J		4 in. x 6 in. Mark AN-I		5 in. x 6 in. Mark AN-K		6 in. x 6 in. Mark AN-L		Name of Part
No. off	Sym. No.	No. off	Sym. No.	No. off	Sym. No.	No. off	Sym. No.	No. off	Sym. No.	No. off	Sym. No.	No. off	Sym. No.	No. off	Sym. No.	
1	KH-E 1	1	KH-F 1	1	KH-G 1	1	KH-H 1	1	KH-J 1	1	AN-I1	1	AN-K1C	1	AN-L1C	Body.
1	AN-E 4	1	AN-F 4	1	AN-G 4	1	AN-H 4	1	AN-J 4	1	BY-D1B	1	BY-D1B	1	BY-D1B	Air Vessel Body.
1	KH-E 5	1	KH-F 5	1	KH-G 5	1	KH-H 5	1	KH-J 5	1	AN-K4	1	AN-K4	1	AN-K4	Plunger.
1	AN-E 5	1	AN-F 5	1	AN-G 5	1	AN-H 5B	1	AN-J 5B	1	AN-K4	1	AN-K4	1	AN-K4	Cylinder Head.
2	KH-E 6	2	KH-E 6	2	KH-E 6	2	KH-E 6	2	KH-E 6	2	SE9	2	SE9	2	SE9	Cup Leather Ring — Tapered Bore.
4	XB 7	4	XB 7	4	XB 7	4	XB 7	4	XB 7	4	SD10	1	SD10	1	SD10	Cup Leather Ring — Parallel Bore.
2	KH-E 8	2	KH-E 8	2	KH-E 8	2	KH-E 8	2	KH-E 8	2	SD10	1	SD10	1	SD10	Suction Valve Seat.
2	KH-E 9	2	KH-E 9	2	KH-E 9	2	KH-E 9	2	KH-E 9	2	AN-K11	1	AN-K11	1	AN-K11	Valve Spring Washer.
1	KH-E10	1	KH-E10	1	KH-E10	1	KH-E10	1	KH-E10	1	AN-K11	1	AN-K11	1	AN-K11	Discharge Valve Seat.
4	XB11	4	XB11	4	XB11	4	XB11	4	XB11	4	AN-K11	1	AN-K11	1	AN-K11	Discharge Valve Cap Washer.
1	AN-E12	1	XA12	1	AN-G12	1	XB12	1	XC12	1	AN-K11	1	AN-K11	1	AN-K11	Top Clamp.
4	XB13	4	XB13	4	XB13	4	XB13	4	XB13	4	AN-K11	1	AN-K11	1	AN-K11	Packing Gland.
2	XA14	2	XA14	2	XA14	2	XA14	2	XA14	2	AN-I13	2	AN-K13	2	SD13	Side Clamp.
2	KH-E16	2	KH-E16	2	KH-E16	2	KH-E16	2	KH-E16	2	AN-I14	1	AN-K14	1	SD14	Valve Spring.
2	KH-E17	2	KH-E17	2	KH-E17	2	KH-E17	2	KH-E17	2	SD15	4	SD15	4	SD15	Side Clamp Bolt.
2	KH-E18	2	KH-E18	2	KH-E18	2	KH-E18	2	KH-E18	2	AN-K17	1	AN-K17	1	AN-K17	Barrel.
2	KH-E18	2	KH-E18	2	KH-E18	2	KH-E18	2	KH-E18	2	AN-K17	1	AN-K17	1	AN-K17	Valve Rubber.
2	KH-E18	2	KH-E18	2	KH-E18	2	KH-E18	2	KH-E18	2	AN-K17	1	AN-K17	1	AN-K17	Cup Leather Flange.
2	KH-E18	2	KH-E18	2	KH-E18	2	KH-E18	2	KH-E18	2	AN-K17	1	AN-K17	1	AN-K17	End Plate Sealing Washer.
2	KH-E18	2	KH-E18	2	KH-E18	2	KH-E18	2	KH-E18	2	AN-K17	1	AN-K17	1	AN-K17	Plunger.
2	KH-E18	2	KH-E18	2	KH-E18	2	KH-E18	2	KH-E18	2	AN-K17	1	AN-K17	1	AN-K17	Inspection Port Cover.
2	KH-E18	2	KH-E18	2	KH-E18	2	KH-E18	2	KH-E18	2	AN-K17	1	AN-K17	1	AN-K17	Discharge Valve Retaining Clamp.
2	KH-E18	2	KH-E18	2	KH-E18	2	KH-E18	2	KH-E18	2	AN-K17	1	AN-K17	1	AN-K17	Inspection End Plate.
2	KH-E18	2	KH-E18	2	KH-E18	2	KH-E18	2	KH-E18	2	AN-K17	1	AN-K17	1	AN-K17	Discharge Valve Retaining Clamp Setscrew.
2	KH-E18	2	KH-E18	2	KH-E18	2	KH-E18	2	KH-E18	2	AN-K17	1	AN-K17	1	AN-K17	Discharge Valve Retaining Clamp Setscrew Locknut.
1	KH-E23	1	KH-E23	1	KH-E23	1	KH-E23	1	KH-E23	1	AN-K20	1	AN-K20	1	AN-K20	Air Vessel to Pump Connection Pipe.
1	KH-E23	1	KH-E23	1	KH-E23	1	KH-E23	1	KH-E23	1	AN-K20	1	AN-K20	1	AN-K20	Air Vessel.
1	KH-E23	1	KH-E23	1	KH-E23	1	KH-E23	1	KH-E23	1	AN-K23	1	AN-K23	1	SD23B	Barrel.
1	KH-E23	1	KH-E23	1	KH-E23	1	KH-E23	1	KH-E23	1	AN-K23	1	AN-K23	1	SD24	Valve Seat.
1	KH-E23	1	KH-E23	1	KH-E23	1	KH-E23	1	KH-E23	1	AN-K23	1	AN-K23	1	SD24	Valve Seat.

Parts List for Marks KH-E, KH-F, KH-G, KH-H, KH-I, AN-I, AN-K, KH-J, AN-J, AN-K and AN-L Power Pumps

2½ in. x 5 in. Mark KH-E		3 in. x 5 in. Mark KH-F		3½ in. x 5 in. Mark KH-G		4 in. x 5 in. Mark KH-H		5 in. x 5 in. Mark KH-J		4 in. x 6 in. Mark AN-I		5 in. x 6 in. Mark AN-K		6 in. x 6 in. Mark AN-L		Name of Part
No. off	Sym. No.	No. off	Sym. No.	No. off	Sym. No.	No. off	Sym. No.	No. off	Sym. No.	No. off	Sym. No.	No. off	Sym. No.	No. off	Sym. No.	
1	KH-E25	1	KH-E25	1	KH-E25	1	KH-E25	1	KH-E25	4	SD25	4	SD25	4	SD25	Plunger Rod.
2	AN-G29	2	AN-G29	2	AN-G29	2	AN-G29	2	AN-G29	1	SD26	1	SD26	1	SD26	Valve Guide.
1	KH-E36	1	KH-E36	1	KH-E36	1	KH-E36	1	KH-E36	1	AN-K28	1	AN-K28	1	AN-K28	Packing Gland.
2	SD44	2	SD44	2	SD44	2	SD44	2	SD44	1	AN-K29	1	AN-K29	1	AN-K29	Plunger Nut.
4	AN-G49	4	AN-G49	4	AN-G49	4	AN-G49	4	AN-G49	4	SD30	4	SD30	4	SD30	Plunger Rod Locknut.
2	AN-E55	2	AN-F55	2	AN-G55	2	AN-H55	2	AN-J55	1	AN-K33	1	AN-K33	1	AN-K33	Valve Washer.
1	AN-G58	1	AN-G58	1	AN-G58	1	AN-G58	1	AN-G58	3	SD43	3	SD43	3	SD43	Plunger Rod.
1	AN-E71	1	AN-E71	1	AN-E71	1	AN-E71	1	AN-E71	4	SD44	4	SD44	4	SD44	Cylinder Head.
1	AN-E75	1	AN-E75	1	AN-E75	1	AN-E75	1	AN-E75	7	SD49	7	SD49	7	SD49	Cylinder Head Gasket.
1	KH-E77B	1	KH-E77B	1	KH-E77B	1	KH-E77B	1	KH-E77B	4	SD50	4	SD50	4	SD50	Air Vessel Sealing Washer.
1	KH-E80B	1	KH-E80B	1	KH-E80B	1	KH-E80B	1	KH-E80B	4	SD52	4	SD52	4	SD52	Inspection Port Cover Gasket.
1	KH-E81	1	KH-E81	1	KH-E81	1	KH-E81	1	KH-E81	4	SD54	4	SD54	4	SD54	Packing Washer.
1	KH-E82	1	KH-E82	1	KH-E82	1	KH-E82	1	KH-E82	4	AN-I55	2	AN-K55	2	SD55	Valve Spring.
1	PC193	1	PC193	1	PC193	1	PC193	1	PC193	1	AN-K70	1	AN-K70	1	AN-K70	Valve Rubber.
2	AN-E55	2	AN-F55	2	AN-G55	2	AN-H55	2	AN-J55	1	AN-E71	1	AN-E71	1	AN-E71	Spanner for Valve Guide.
1	AN-G58	1	AN-G58	1	AN-G58	1	AN-G58	1	AN-G58	1	AN-E75	1	AN-E75	1	AN-E75	Pump Bucket.
1	AN-E71	1	AN-E71	1	AN-E71	1	AN-E71	1	AN-E71	1	AN-E75	1	AN-E75	1	AN-E75	Plain End Plate.
1	AN-E75	1	AN-E75	1	AN-E75	1	AN-E75	1	AN-E75	1	AN-E75	1	AN-E75	1	AN-E75	Water By-pass Connection.
1	KH-E77B	1	KH-E77B	1	KH-E77B	1	KH-E77B	1	KH-E77B	1	AN-E75	1	AN-E75	1	AN-E75	Air Valve Screw.
1	KH-E80B	1	KH-E80B	1	KH-E80B	1	KH-E80B	1	KH-E80B	1	AN-E75	1	AN-E75	1	AN-E75	Air Valve Housing.
1	KH-E81	1	KH-E81	1	KH-E81	1	KH-E81	1	KH-E81	2	AN-I55	2	AN-K55	2	SD55	Water By-pass Valve Stem and Handle Assembly.
1	KH-E82	1	KH-E82	1	KH-E82	1	KH-E82	1	KH-E82	1	AN-K70	1	AN-K70	1	AN-K70	Water By-pass Valve Seat (not illus.).
1	PC193	1	PC193	1	PC193	1	PC193	1	PC193	2	KBB100	2	KBB100	2	KBB100	Water By-pass Valve Stem Sealing Ring.
2	AN-E55	2	AN-F55	2	AN-G55	2	AN-H55	2	AN-J55	2	PC193	1	PC193	1	PC193	Water By-pass Valve Seat Washer (not illus.).
1	AN-G58	1	AN-G58	1	AN-G58	1	AN-G58	1	AN-G58	1	PC193	1	PC193	1	PC193	Water By-pass Connec. Gasket.
1	AN-E71	1	AN-E71	1	AN-E71	1	AN-E71	1	AN-E71	1	YC220	1	YC220	1	YC220	Air Valve Spring.
1	AN-E75	1	AN-E75	1	AN-E75	1	AN-E75	1	AN-E75	1	YC221	1	YC221	1	YC221	Water Cock Packing Gland.
1	KH-E77B	1	KH-E77B	1	KH-E77B	1	KH-E77B	1	KH-E77B	1	YC221	1	YC221	1	YC221	Water Cock Packing Nut.
1	KH-E80B	1	KH-E80B	1	KH-E80B	1	KH-E80B	1	KH-E80B	1	YC223B	1	YC223B	1	YC223B	Water Cock Valve Stem.
1	KH-E81	1	KH-E81	1	KH-E81	1	KH-E81	1	KH-E81	1	YC224	1	YC224	1	YC224	Water Cock Valve Stem Handle.
1	KH-E82	1	KH-E82	1	KH-E82	1	KH-E82	1	KH-E82	1	YC225B	1	YC225B	1	YC225B	Water Cock Valve.
1	PC193	1	PC193	1	PC193	1	PC193	1	PC193	1	YC228	1	YC228	1	YC228	Water Cock Gland Washer.
2	AN-E55	2	AN-F55	2	AN-G55	2	AN-H55	2	AN-J55	1	YC246	1	YC246	1	YC246	Air Vessel Drain Plug.
1	AN-G58	1	AN-G58	1	AN-G58	1	AN-G58	1	AN-G58	1	YC247	1	YC247	1	YC247	Air Vessel Drain Plug Washer.
1	AN-E71	1	AN-E71	1	AN-E71	1	AN-E71	1	AN-E71	1	YC247	1	YC247	1	YC247	Drain Plug.

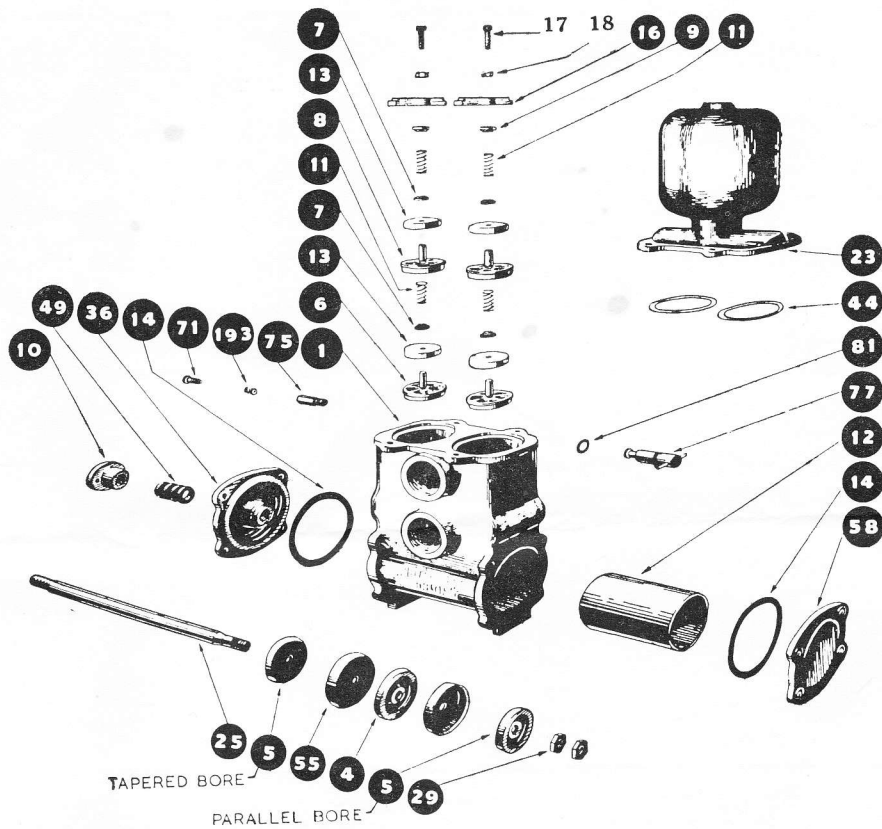

Marks KH-E, KH-F, KH-G, KH-H and KH-J Power Pump Parts

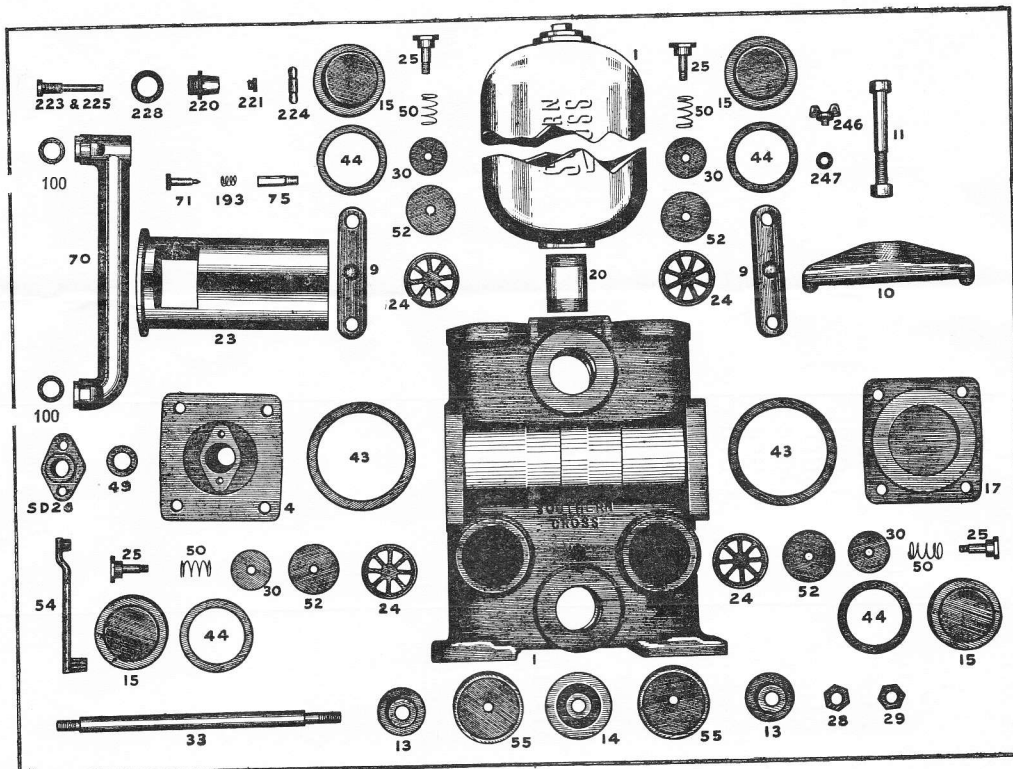

Marks AN-I, AN-K and AN-L Power Pump Parts

Parts List for Mark AL-E, AL-G Drive Gear.

Mark AL-E Drive Gear fitted to Fig. 3187 Power Pumps—5in. Stroke.

Mark AL-G Drive Gear fitted to Fig. 2550 Power Pumps—6in. Stroke.

Mark AL-E		Mark AL-G		Name of Part
No. off	Sym. No.	No. off	Sym. No.	
1	AL-E1C	1	AL-G1C	Gearbox.
1	AL-E2	1	AL-G2	Gearbox Cover.
1	AL-E3B	1	AL-G3B	Pinion.
1	AL-E4B	1	AL-G4B	Pinion Shaft.
1	AL-E5	1	AL-G5B	Pinion Shaft Long Bearing.
1	AL-E6	1	AL-G6B	Pinion Shaft Short Bearing.
1	AL-E7B	1	AL-G7B	Gearwheel.
1	AL-E10	1	AL-G10	Gearwheel Shaft.
2	AL-E11	2	AL-G11	Gearwheel Shaft Bearing.
1	AL-E12	1	AL-G12	Eccentric Cover Plate.
1	AL-E13	1	AL-G13	Connecting Rod.
1	AL-E14	1	AL-G14	Connecting Rod Small End Bush.
1	AL-E15	1	AL-G15	Crosshead.
1	AL-E16	1	AL-G16	Crosshead Pin.
1	AL-E17	1	AL-G17	Crosshead Pin Locking Screw.
1	AL-E18	1	AL-G18	Splash Guard.
2	AL-E21	2	AL-G21	Gearbox Pump End Cover Plate.
1	AL-E22			Gearwheel Key.
1	AL-E23B			Vee Pulley: AL-E23B 21½in. P.C.D. x 4 A Grooves.
1	AL-E24			Plunger Rod Locking Setscrew.
1	AL-E24	1	AL-E24	Splash Guard Setscrew.
1	AL-E25	1	AL-G26	Pulley Setscrew (1½in. x ½in. Whit.).
1	AL-E26	1	AL-G27	Dipstick Assembly.
1	AL-E27	1	AL-G29	Gearbox Gasket.
4	AL-E29	4	AL-G29	Gearbox Bearing Gasket.
1	AL-E31B	1	AL-G31	Flat Pulley: AL-E31B 21½in. Dia. x 4in. Face; AL-G31, 23in. Dia. x 6in. Face.
1	AL-E33	1	AL-G33	Vee Pulley: AL-E33, 21½in. P.C.D. x 6 B Grooves; AL-G33, 21½in. P.C.D. x 6 B Grooves.
		1	AL-G36	Vee Pulley, 28½in. P.C.D. x 5 C Grooves.
2	AL-E38B	2	AL-G38	Electric Motor Base Rails.
3	AL-G511	3	ALG-511	Eccentric Cover Setscrew.
1	AQ-E512	1	AQ-E512	Pulley Setscrew (1½in. x ½in. Whit.).
1	AL-G513	1	AL-G513	Pulley Setscrew (2in. x ½in. Whit.).
1	AL-G514	1	AL-G514	Plunger Rod Locking Setscrew.

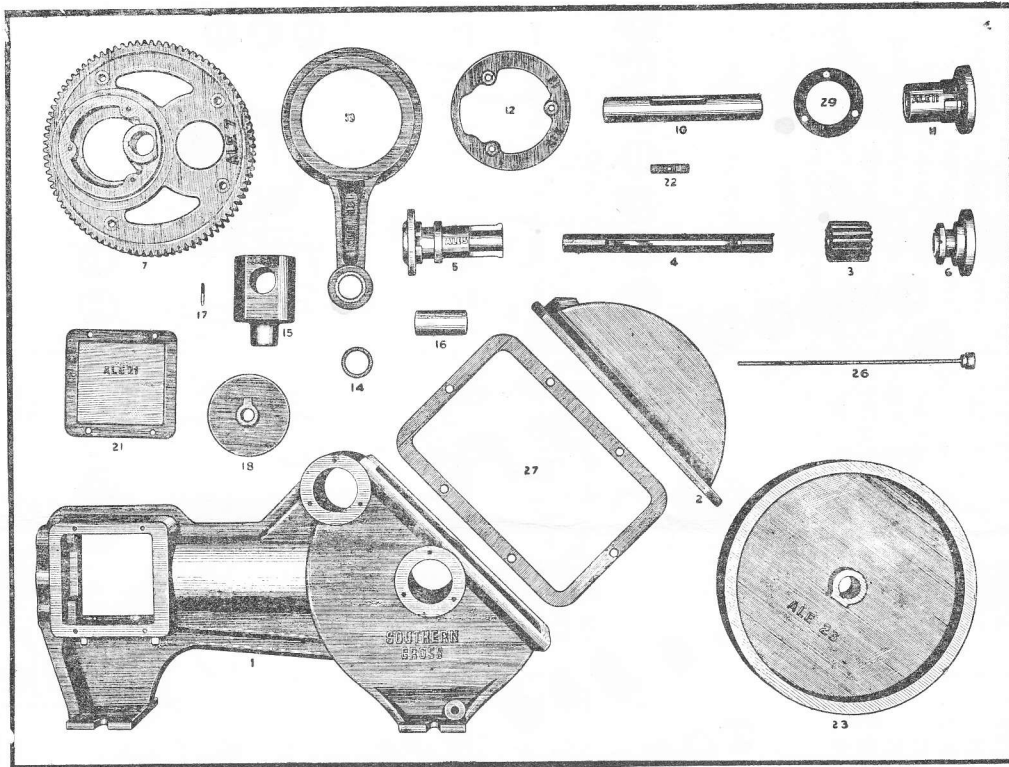

Marks AL-E and AL-G Drive Gear Parts.

THE SOUTHERN CROSS ORGANISATION

SALES AND SERVICE COMPANIES

<p>TOOWOOMBA (Qld.) SOUTHERN CROSS MACHINERY (TOOWOOMBA) PTY. LTD. Cnr. Campbell & Ruthven Streets, Toowoomba 4350.</p>	<p>CAIRNS (Qld.) SOUTHERN CROSS MACHINERY (TOWNSVILLE) PTY. LTD. 186 Lyons Street, Cairns 4870.</p>	<p>MELBOURNE (Vic.) SOUTHERN CROSS MACHINERY PTY. LTD. 133-135 McIntyre Road, Sunshine 3020</p>
<p>BRISBANE (Qld.) SOUTHERN CROSS MACHINERY (BRISBANE) PTY. LTD. Cnr. Ipswich & Ashover Roads, Rocklea 4106.</p>	<p>GRANVILLE, SYDNEY, (N.S.W.) SOUTHERN CROSS MACHINERY PTY. LTD. 1 Grand Avenue, Granville 2142</p>	<p>WARRNAMBOOL (Vic.) SOUTHERN CROSS MACHINERY PTY. LTD. Cnr. Fairy & Merri Streets, Warrnambool 3280.</p>
<p>CHARLEVILLE (Qld.) SOUTHERN CROSS MACHINERY (TOOWOOMBA) PTY. LTD. Alfred Street, Charleville 4470.</p>	<p>CITY OFFICE, SYDNEY, (N.S.W.) SOUTHERN CROSS MACHINERY PTY. LTD. 22 Young Street, Sydney 2000.</p>	<p>HINDMARSH (S.A.) SOUTHERN CROSS MACHINERY PTY. LTD. 173 Port Road, Hindmarsh 5007.</p>
<p>ROCKHAMPTON (Qld.) SOUTHERN CROSS MACHINERY PTY. LTD. 298 Bolsover Street, Rockhampton 4700.</p>	<p>MOREE (N.S.W.) SOUTHERN CROSS MACHINERY PTY. LTD. 209-215 Gwydir Highway, Moree 2400.</p>	<p>MAYLANDS (W.A.) SOUTHERN CROSS MACHINERY PTY. LTD. 290-298 Whatley Crescent, Maylands 6051.</p>
<p>TOWNSVILLE (Qld.) SOUTHERN CROSS MACHINERY (TOWNSVILLE) PTY. LTD. 351-353 Flinders Street, Townsville 4810.</p>	<p>TAMWORTH (N.S.W.) SOUTHERN CROSS (TAMWORTH) PTY. LTD. 476 Peel Street, Tamworth 2340.</p>	<p>SOUTH AFRICA SOUTHERN CROSS WINDMILL & ENGINE CO. (PTY.) LTD. Bloemfontein, Johannesburg, Port Elizabeth, Capetown and Windhoek.</p>