

Instruction Manual for...

SOUTHERN CROSS



GENERATING SETS

Fig. 3108 1.5K.W. 110/240 Volt Direct Supply Generating Set

Fig. 3109 1.5K.W. 110 Volt Battery Charging Generating Set

FIG. 3108 1.5 K.W. 110'240 VOLT DIRECT SUPPLY GENERATING SETS

Installation

Foundation for Set

To obtain the best results from this set, install it on a firm foundation. A large block of concrete with the foundation bolts set into it, makes a suitable foundation.

To Make Concrete Block

1. After deciding where the set is to be installed, sink a hole in the ground 1ft. to 1ft. 6in. deep and to the sizes on the General Arrangement Illustration on Page 2. Light soil requires a larger base than heavy, well-packed soil, but always make the block larger for preference.
2. Make a wooden template to hold the foundation bolts in their correct positions while the concrete is being poured. (Refer to Illustration on this page). Slide the base on to the template, and, using a $\frac{1}{8}$ inch bit, mark the positions for the holes. Remove the base and bore $\frac{1}{2}$ inch holes through the template.
3. Place template in position over the hole in the ground. Take the foundation bolts from the engine case, put large washers on them and then hang them from the template so the tops will project 3 inches above the concrete when the template is removed.
4. Drive in some small pegs around the ends of the crossboards to hold the template in position. Check that the template is level with a spirit level and pack under the ends if necessary.
5. Mix a batch of concrete, using 4 parts sharp stone or rubble, 2 parts sand and one part cement. See that the stone and sand are clean and do not contain any clay or dirt. If they do, wash carefully before mixing. A block 1ft. 6in. deep will require approximately 4 bags of cement, $\frac{1}{4}$ yard of sand and $\frac{1}{2}$ yard of stone.
6. Fill the hole with concrete, and at the same time place old bars and bolts in for reinforcements.
7. Allow the concrete to set for two or three hours and then carefully lift off the template, taking care not to disturb the bolts. If necessary, smooth off the top of the block, using a mixture of 2 parts sand and one part cement. Allow the concrete to set for a day.

Lining Up the Set

1. Lift the base into position on the concrete block, and with a spirit level, check that the base is level. Where necessary place thin pieces of tin under the edge of the base to level it, and then tighten down the nuts on the foundation bolts.

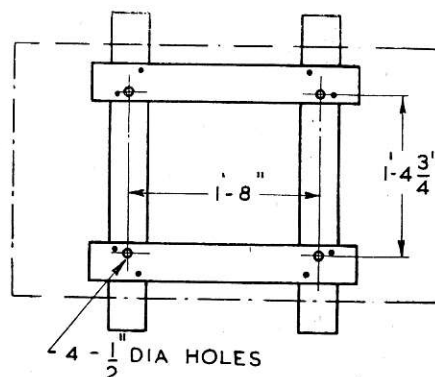

Bolt Template for Generating Set

2. Take the studs supplied in the generator box and screw them into the base, short-threaded end first. To tighten the studs into the base, screw two nuts on to each stud in turn, lock them together, tighten stud using the spanner on the top nut and then unlock nuts.
3. Unscrew the cylinder head cover nut on the engine, lift off the cylinder head cover and screw on the lifting shackle. Then lift the engine on to the base and replace the cover and nut.
4. Clean the face of the engine flywheel and fit the driving half of the flexible coupling. Screw it on to the engine crankshaft and tighten, using the starting handle as a tommy bar.
5. Slide the other half of the coupling on to the generator shaft and see that the key is in position. Fit the coupling disc on to the driving pegs and lift the generator on to the base.
6. The two halves of the coupling are the same diameter, so that if the diameters coincide, the engine and generator must be in line. By checking with a straight edge on top, underneath and on either side, line up the coupling. The generator can be raised as required, using the packing shims supplied. Take particular care with the lining-up, as accuracy is important.
7. When the lining-up is correct, bolt the engine and generator down and re-check the lining-up. When bolting the engine down, fit spring washers under the nuts.
8. Shift the driven half of the coupling along so that the coupling disc slides on to the other set of pins and is gripped tightly between the two halves of the coupling. Then ease the driven half back just enough so that the disc is free, and lock it in this position.

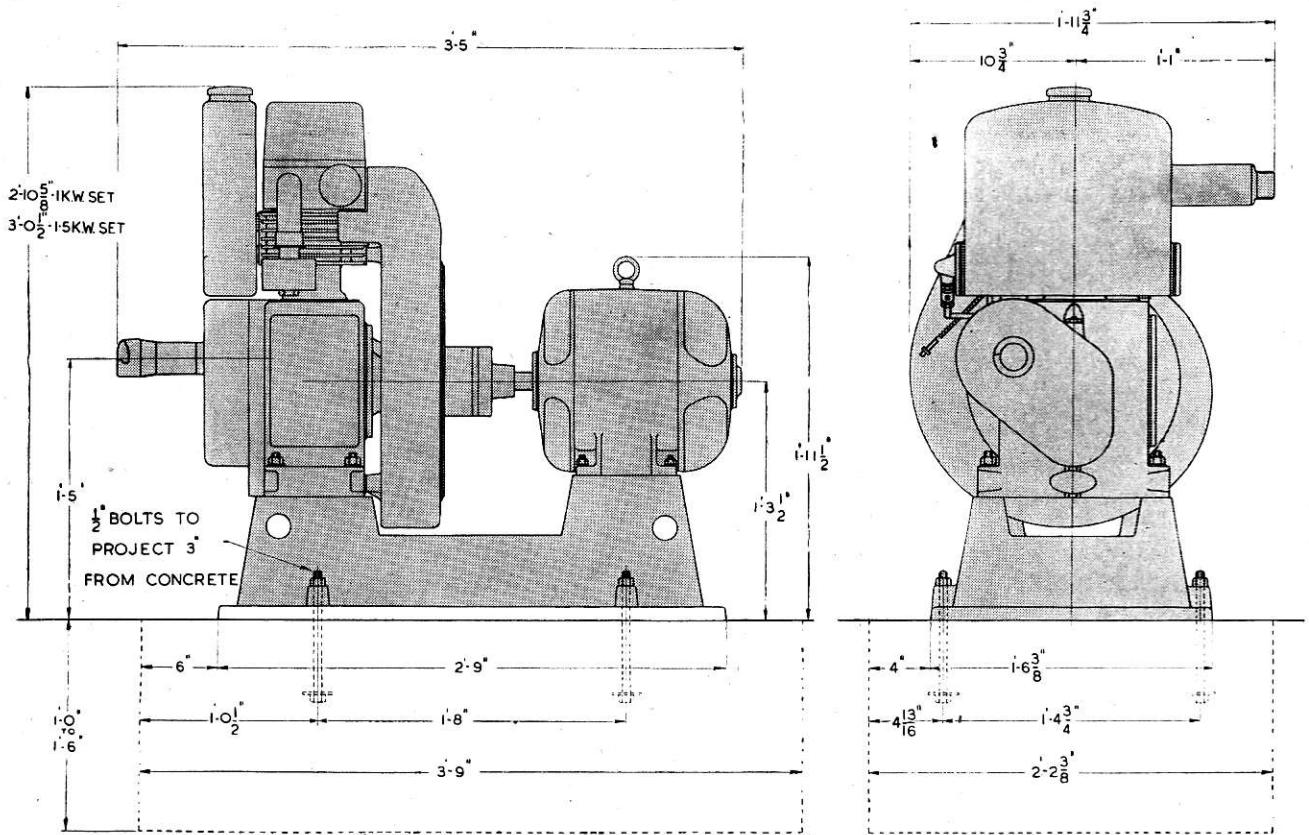

General Arrangement of Fig. 3108 1.5 K.W. 110/240 Volt Direct Supply Generating Sets and Fig. 3109 1.5 K.W. 110 Volt Battery Charging Generating Set

Mounting Switchboard on Wall

The Switchboard must be mounted vertically on the wall in a convenient position close to the generating set. Fix suitable bearers of about 3in. x 2in. timber at a convenient height, and then bolt the switchboard to the bearers, using the bolts supplied.

Wiring Up Set

1. Remove the small panel from the front of the switchboard to expose the terminal strip. Also remove the cover from the generator terminal box.
2. Refer to the wiring diagram at the top of the illustration on Page 3, which shows the necessary connections.

Use 7/.029 wiring between the Switchboard and Generator.

It is recommended that the wiring between the Generator and switchboard be run in conduit; and where there is a concrete floor, the conduit can be concreted in if screwed conduit is used. The bottoms of the generator terminal box and the switchboard are drilled for conduit connections. It may be necessary to use a short length of flexible conduit to connect to the generator terminal box. After fitting the conduit, but before joining the pieces together, push a piece of wire through them so that the main connection leads can be pulled through.

The size of the overhead lines to the house will vary according to the distance the set is installed from

the house. The table below shows the maximum distances the generating set can be from the house using the different wire sizes, to ensure good lights.

Size of Set	Wire Sizes			
	7/.064	7/.080	7/.092	7/.104
1.5 K.W. 110 Volt	1,000ft.	1,600ft.	2,050ft.	2,650ft.

Size of Set	Wire Sizes			
	7/.036	7/.044	7/.048	7/.052
1.5 K.W. 240 Volt	1,500ft.	2,250ft.	2,750ft.	3,150ft.

Hard Drawn Bare Copper Cable may be used for overhead lines if the installation is made according to S.A.A. Wiring Rules, and the installing electrician should be consulted about this matter.

Separate small loads such as lights in outbuildings may be wired up, using separate small overhead lines. Consult the installing electrician about the size of these overhead lines.

Earthing: Connect a wire between the terminal marked E on the switchboard terminal strip, and one of the studs which hold the generator terminal box in place. Also continue this wire and connect it to a piece of iron or copper bar driven into the ground outside the building.

The above connection earths only the frames of the switchboard and generator to avoid any possibility of shock should a leak occur. It does not earth either the positive or negative line.

If it is desired to earth the negative line for any reason, this can be done by making the connections shown above, and in addition, connecting the terminal N to the terminal E on the switchboard terminal strip. Consult the installing electrician about your particular earthing requirements.

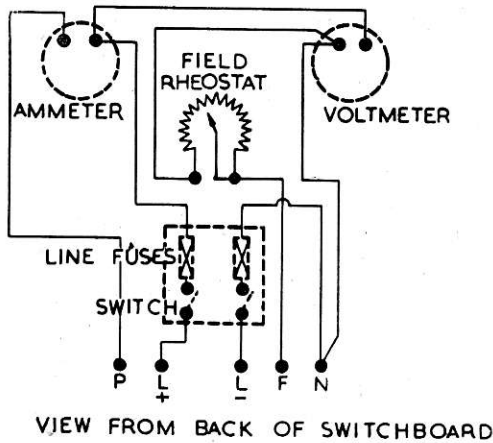

VIEW FROM BACK OF SWITCHBOARD

Switchboard Wiring Diagram

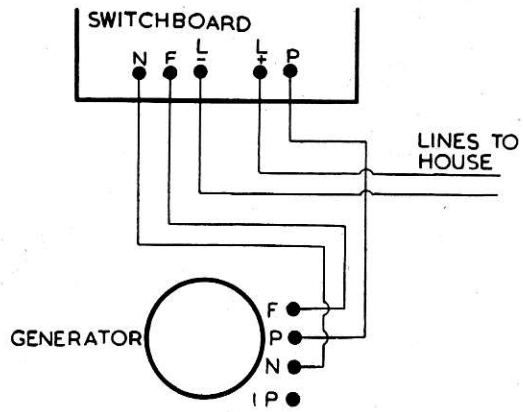

Interconnection Wiring Diagram

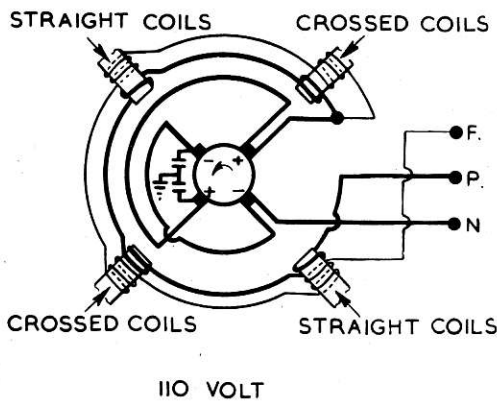

VIEW FROM COMMUTATOR END

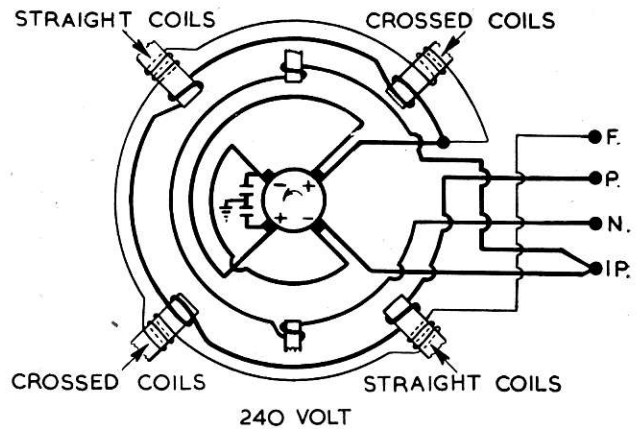

VIEW FROM COMMUTATOR END

Generator Wiring Diagrams.

Wiring Diagram for Fig. 3108 1.5 K.W. 110/240 Volt Direct Supply Generating Set.

Running Instructions

To Start Set

Carefully carry out the instructions given under the heading "Running Instructions" on Page 6 of the Engine Instruction Manual.

Start the engine and then turn the field rheostat knob on the switchboard in a clockwise direction until the voltmeter reading rises to the particular voltage of the set, i.e., 110 volt for a 110 volt set and 240 volts for a 240 volt set.

The main switch can then be switched on, and the lights, etc., used. When the load is applied the voltmeter reading may be slightly reduced. A small variation from the original setting is not important, but where desired the field rheostat knob can be re-adjusted to give the original setting.

The ammeter reading shows the amount of load on the set. Never allow the load to exceed the full load current of the set, i.e., 13.6 amps for a 110 volt set or 6.2 amps for a 240 volt set.

To Stop Set

Switch off the main switch on the switchboard and stop the engine as shown on Page 6 of the Engine Instruction Manual.

Fuses

The two fuses provided inside the main switch are connected in the circuit of the lines to the house, so if they blow at any time it will not be possible to use any power at the house.

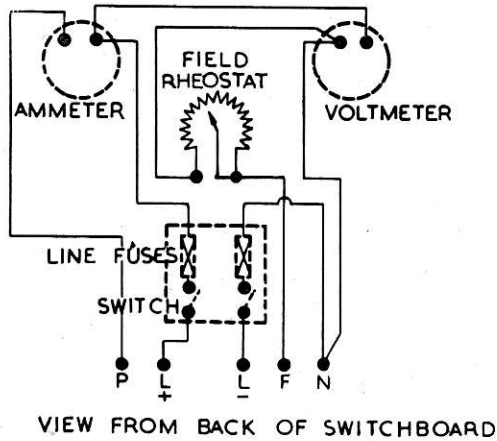

VIEW FROM BACK OF SWITCHBOARD

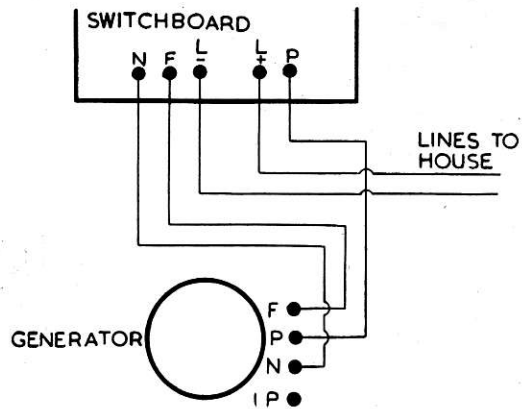
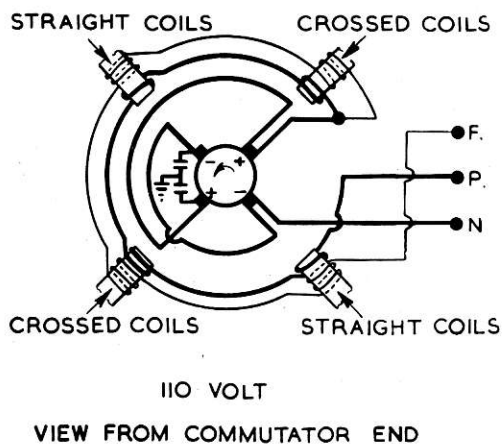
Switchboard Wiring Diagram*Interconnection Wiring Diagram*

110 VOLT

VIEW FROM COMMUTATOR END

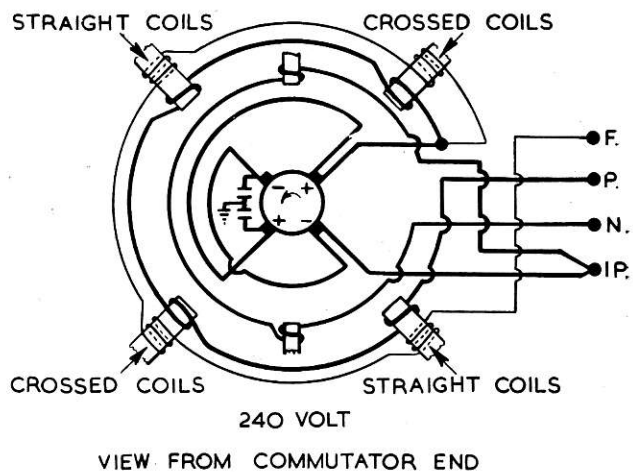

240 VOLT

VIEW FROM COMMUTATOR END

Generator Wiring Diagrams.

Wiring Diagram for Fig. 3108 1.5 K.W. 110/240 Volt Direct Supply Generating Set.

Running Instructions

To Start Set

Carefully carry out the instructions given under the heading "Running Instructions" on Page 6 of the Engine Instruction Manual.

Start the engine and then turn the field rheostat knob on the switchboard in a clockwise direction until the voltmeter reading rises to the particular voltage of the set, i.e., 110 volt for a 110 volt set and 240 volts for a 240 volt set.

The main switch can then be switched on, and the lights, etc., used. When the load is applied the voltmeter reading may be slightly reduced. A small variation from the original setting is not important, but where desired the field rheostat knob can be re-adjusted to give the original setting.

The ammeter reading shows the amount of load on the set. Never allow the load to exceed the full load current of the set, i.e., 13.6 amps for a 110 volt set or 6.2 amps for a 240 volt set.

To Stop Set

Switch off the main switch on the switchboard and stop the engine as shown on Page 6 of the Engine Instruction Manual.

Fuses

The two fuses provided inside the main switch are connected in the circuit of the lines to the house, so if they blow at any time it will not be possible to use any power at the house.

FIG. 3109 1.5 K.W. 110 VOLT BATTERY CHARGING GENERATING SET

Installation

The instructions for the installation of this set are the same as given on Pages 1 and 2, with the exception of the Section, "Wiring Up the Set." Wiring instructions for this set are given below.

Do not place the battery under the switchboard as the acid fumes may affect the board.

Setting up the Battery

Make a suitable stand for the battery. It is recommended that the stand be painted with acid-proof paint.

Connect the cells together, making sure they are connected correctly, that is, positive terminal of one cell to the negative of the next cell. Use the flexible connections between the end cells of the rows.

Tack the battery instruction chart on the wall behind the battery.

Make a small bracket to support the hydrometer by its bulb, allowing it to hang free without any risk of breaking.

Wiring Up Set

1. Remove the small panel from the front of the switchboard to expose the terminal strip. Also remove the cover from the generator terminal box.
2. Refer to the wiring diagram at the top of Page 5, which shows the necessary connections. Use 7/.036 wiring between the Switchboard and Generator and the Switchboard and Battery. The connections between the Switchboard and Push Button can be made using 3/.029 wire.

NOTE: The Push Button may be placed up to 75 yards from the Set.

It is recommended that the wiring between the generator and switchboard be run in conduit; and where there is a concrete floor, the conduit can be concreted in if screwed conduit is used. The bottoms of the generator terminal box and switchboards are drilled for conduit connections. It may be necessary to use a short length of flexible conduit to connect to the generator terminal box. After fitting the conduit, but before joining the pieces together, push a piece of wire through them so that the main connection leads can be pulled through.

Tough Rubber Sheathed Cable (T.R.S.) may be used between the Switchboard and the Battery.

Hard Drawn Bare Copper Cable may be used for overhead lines where there is no likelihood of personal contact, and the installing electrician should be consulted about this matter.

The size of the overhead lines to the house will vary according to the distance the set is installed from the house. The table below shows the maximum distances the generating set, with the battery in the engine room, can be from the house to ensure good lights.

WIRE SIZES			
7/.064 1,000ft.	7/.080 1,600ft.	7/.092 2,050ft.	7/.104 2,650ft.

*Maximum Distances between Set and House for
Different Wire Sizes
(Battery in Engine Room)*

The battery may be installed at the house, if desired, but if it is the engine cannot be electrically started. **With the battery at the house**, the maximum distances the generating set can be placed from the house are as follows:

WIRE SIZES				
7/.044 900ft.	7/.048 1,100ft.	7/.052 1,350ft.	7/.064 2,000ft.	7/.080 3,200ft.

*Maximum Distances between Set and House for
Different Wire Sizes
(Battery at House)*

Separate small loads such as lights in outbuildings may be wired up, using separate small overhead lines. Consult the installing electrician about the size of these overhead lines.

Earthing: Connect a wire between the terminal marked E on the switchboard terminal strip, and one of the studs which holds the generator terminal box in place. Also continue this wire and connect it to a piece of iron or copper bar driven into the ground outside the building.

The above connection earths only the frames of the switchboard and generator to avoid any possibility of shock should a leak occur. It does not earth either the positive or negative line. If it is desired to earth the negative line for any reason, this can be done by making the connections shown above and in addition connecting the common N, L —, B —, terminals to the terminal E on the switchboard terminal strip. Consult the installing electrician about your particular earthing requirements.

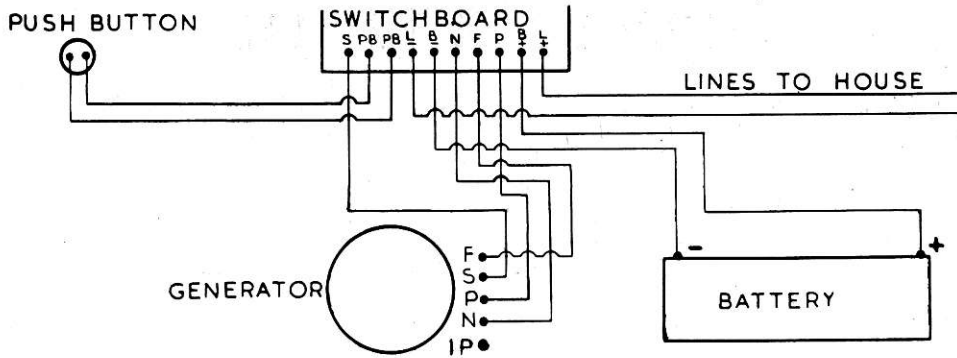

Interconnection Wiring Diagram

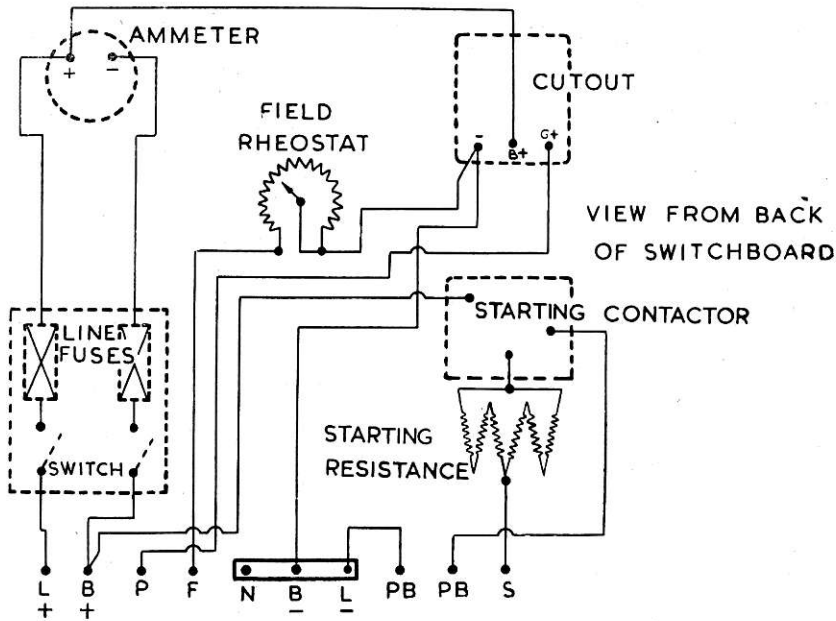

Switchboard Wiring Diagram

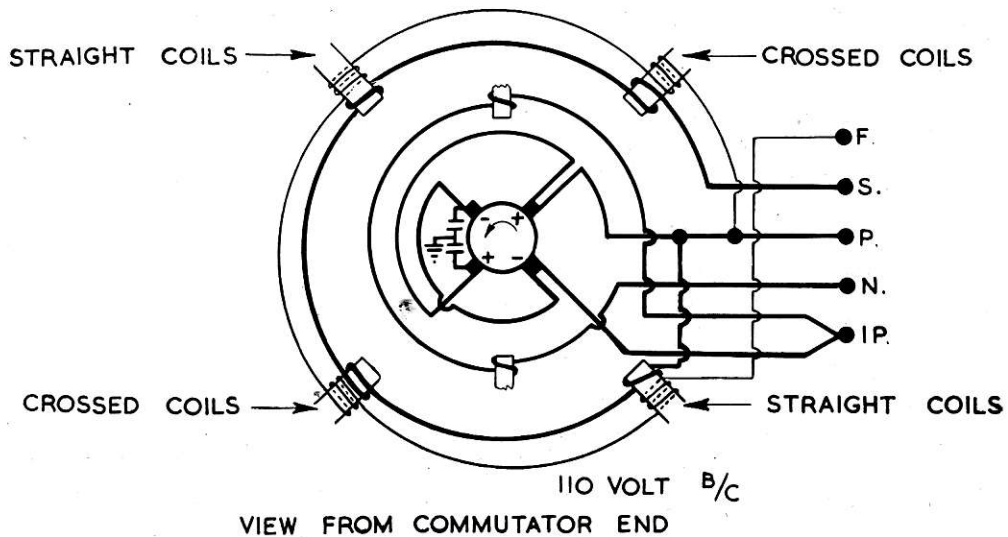

Generator Wiring Diagram

Running Instructions

Operating Switchboard

Main Switch: The generator will electric start the engine with the main switch in the "off" position, but no load can be taken from the battery unless the main switch is switched to the "on" position.

Ammeter: The ammeter indicates the charge to or discharge from the battery. The readings will vary and depend on:

- (a) Whether or not the set is charging.
- (b) The amount of load at the house.
- (c) The setting of the field rheostat (when set is charging).

Field Rheostat: The Field Rheostat is used to control the charge to the battery. To increase the charge, turn the rheostat knob in a clockwise direction and vice-versa.

Fuses: Two fuses are provided inside the main switch case. The right hand one looking at the front of the switchboard is connected in the circuit of the lines to the house and if it blows at any time, neither the battery nor the generator can supply light, but the battery can be charged. The left hand fuse is connected in the battery circuit, and if it is blown, the battery cannot be charged, and it will not supply light. The generator will still electric start the engine with either or both of the fuses blown.

To Start Set

1. Prepare engine for the first run as detailed in the Engine Instruction Manual.
2. See that the Fuel Cock is on.
3. See that the fuel pump control rod stop is in the running position. (Refer to Engine Instruction Manual). If this is not done the engine will be difficult to start, and it will not receive sufficient fuel.
4. Pour sufficient lubricating oil into the starter plug to fill it, then put into cylinder head cover. Two fillings may be necessary in cold weather but never use more than two fillings of oil or pour oil in while the engine is running, otherwise the engine may be damaged.
5. Press push button, and as soon as the engine commences to fire, release the push button. If the engine does not commence firing then the instructions for preparing the engine for first run in the Engine Instruction Manual have not been followed.

NOTE:

- (a) Do not hold the push button closed for more than about thirty seconds at a time.
- (b) After each attempt to start, allow the battery to stand idle for at least one minute while the engine is checked over to see why it did not start.

If a battery is not installed, the engine must be cranked by hand as detailed in the Engine Instruction Manual.

To Stop Set

Stop engine as detailed in the Engine Instruction Manual.

Charging the New Battery

Although the new cells are fully charged when supplied by the manufacturer they may lose some of their

charge during the time they are standing before they are installed. Therefore the new battery should be put on charge as soon as possible.

To charge the battery proceed as follows:

1. Read the recommended level for the electrolyte shown on the Battery Instruction Chart, and then check each cell. If necessary, add pure distilled water to correct the level.
2. Start set as shown in instructions, "To Start Set."
3. Adjust the Field Rheostat knob until the charging rate shown on the ammeter rises to the Finish Charging Rate (usually half the normal charging rate) specified on the Instruction Chart supplied with the battery.
4. Charge for one hour and then check the specific gravity of each cell with the hydrometer supplied with the battery. Continue charging until the specific gravity reaches the fully charged specific gravity given on the Battery Instruction Chart. If the charging rate has dropped while charging, reset it and then stop the set **leaving the field rheostat knob at the set position.**

When Battery Should Be Charged

Daily checking of the specific gravity of the cells with the hydrometer will show when it is necessary to charge. **Never allow the specific gravity to drop below the recommended recharging figure shown on the battery Instruction Chart or allow periods between charging to exceed one week.**

When charging does become necessary, proceed as follows:

1. With the Field Rheostat knob still set as for the first charging, start the set. The ammeter will show a much higher charge than the setting made during the first charging. This is quite normal, and as the battery becomes charged the rate will drop. When the battery is fully charged the rate will have dropped to the recommended Finish Charging Rate.
2. With the Field Rheostat set as above, it may be found that the rate during the earlier part of the charging may be below the Maximum Charging Rate shown on the Battery Instruction Chart. In this case, adjustment of the rate to the maximum recommended rate will give faster charging. **IMPORTANT: The Maximum Charging Rate must not be exceeded, and when the cells start gassing freely, reduce the rate to the Finish Charging Rate.**
3. Charge until the specific gravity rises to the fully charged figure, and then stop the set.
4. **Once every month** continue the charging until the specific gravity of all the cells is up to the fully charged figure. In cases where one or two cells have less charge than the rest it may be necessary to continue charging from one to four hours after the rest are fully charged. While making this extra charge, feel the cells with a bare hand, and if they get noticeably warmer, reduce the charging rate. Take readings of the specific gravity every half hour and charge until the lagging cells stop rising. Where a cell will not come up to full charge it is likely that some fault has developed in the cell. In this case consult the Battery Manufacturer. **DANGER: Keep naked lights away from the tops of the cells, otherwise there may be an explosion.**

General Instructions for All Sets

Care of the Generator

In order to ensure trouble-free operation of the Generator it is necessary to observe a certain maintenance routine.

Cleaning

Keep all parts of the generator clean. It is most important that the commutator be kept free from dust and dirt. The commutator, brushes, brush holders and spindles, windings and terminals should be periodically wiped down with a clean, dry rag.

Bearings

When the Generator leaves the works the bearings are packed with grease, and do not require further attention before the plant is put into operation.

However, it is advisable to remove the end caps from the bearings about once a year to examine them. The balls and races should be clean and show no signs of rusting. There need only be a smear of grease on the bearing. If necessary, grease should be added to the bearing. Only fill the bearing cage, don't fill the cap with grease, or the bearing will overheat and grease will be forced from the bearing over the windings of the Generator.

The faults from over lubrication of ball bearings are far greater than those occurring from under lubrication. Under no condition must oil or grease containing graphite be used.

Recommended grease is:

SOUTHERN CROSS GREASE.

Wakefield Spherol HM.

Ampolgrease BER.

Gargoyle Grease No. 3.

Caltex Star Grease No. 3.

Shell Retinax A.

Atlantic Ball Roll Medium.

Neptune Tenac MP.

Brushes

Keep the Brushes free in their holders and all even in pressure. When worn down to less than $\frac{5}{16}$ in. long they should be replaced with new brushes of the size and grade stamped on the name plate.

To Fit New Brushes

1. Remove the covers from the Commutator End End-Shield.
2. Remove the brushes from the holders. Loosen nuts which hold the brush leads to the brush holders and remove them.
3. Try new brushes of the size and grade shown on the name plate in the brush holder.
4. They should slide freely without sticking. If they are tight, ease them down carefully by rubbing the tight side lightly on a flat sheet of fine sand paper until they will just slide in the holder.
5. Put the brushes in the holder and connect the brush leads to the brush holders.
6. Place a piece of sand paper, sand side out, around the commutator, and allow the brushes to seat on the sand paper.
7. Carefully draw the paper backwards and forwards until the brushes assume the correct curvature, taking care to keep it round the commutator so that a flat is not formed in the brush. When the process is nearly completed, fine glass paper should be used to obtain a very smooth finish.
8. After bedding carefully, clean away every trace of dust from the Commutator, Brushes and Holders. Make sure no specks of abrasive material are embedded in the face of the brush.
9. Replace the covers on the endshield and the generator may be started. It is advisable to run it on light load for a few hours before putting on full load to enable the brushes to settle down properly.

Troubles and Their Remedies

A. Sparking at the Brushes

The commutator should be examined occasionally while the plant is running. It should be practically sparkless at all times. If sparking does occur, steps should be taken to cure it or serious trouble may arise in a short time. Sparking may be due to several causes:

1. **Overload of Generator.**
Reduce load and observe whether sparking reduces.
2. **Jumping of Brushes due to Vibration.**
To check for this trouble, proceed as follows: Place a finger lightly on the brush tension arm. If vibration is felt and if the sparking decreases with the added pressure, the sparking is probably caused by vibration. In this case, tighten the screw on the brush holder to increase the tension on the brush.
3. **Brushes not Sliding Freely in the Brush Holder.**
If the Generator is used in dusty conditions the brushes may become jammed in the holders with dust. Remove and clean both holders and brushes.
4. **Wrong Grade of Brushes Being Used.**
Use only the grade of Brush which is specified on the nameplate.
5. **Brush Holders Assembled Wrong Way Around on Spindle after an Overhaul.**
Brushes should run directly opposite the centre of the field pole.

B. No Power at House (Direct Supply Sets Only)

Check the following in order:

1. See that main switch is ON.
2. Open the main switch case on the switchboard and check the fuses.
3. Make sure there are no loose connections on the terminal strip in the switchboard and generator terminal box.

C. Generator will not Charge the Battery, or there is no Power at the House (Battery Charging Sets Only)

Check the following in order:

1. See that main switch is ON.

2. Open the main switch case on the switchboard and check the fuses.
3. Make sure there are no loose connections on the terminal strip in the switchboard and generator terminal box. Also check that there are no loose or dirty connections between the cells.

D. Radio Interference.

D.C. Generators and motors, when running, cause radio interference, and if this interference is allowed to get into the radio set it may result in so much noise that radio stations become inaudible behind the interference.

Radio interference may be suppressed, but it is almost impossible to completely eliminate it. The greater the degree of suppression required — the more expensive it becomes.

However, interference can be minimized by careful installation. When buying your radio set, get your radio man to suggest the best installation for your particular case.

The following items should be carefully studied before installing your radio, to make sure that interference is minimized.

1. Locate the receiving aerial as far away as possible from the generating plant, and run it at right angles (not parallel) to the power lines from the engine shed to the house, keeping the aerial as high as possible. Use shielded wire from the lead-in to the house right to the set, or use the aerial filters and twin lead-in wires which are available from your radio store. Consult your radio man on this point and use the type of lead-in he recommends.
2. Make sure the generator and switchboard frames are effectively earthed (refer "Earthing," instructions on Pages 2 and 4).
3. Keep the commutator and brush gear clean. Ensure that brushes are free in their holders, and that there is no excessive sparking. Brushes sticking in the holders will spark badly, and will burn away and cause interference.
4. In new installations, it will be found that the noise will lessen over the first few weeks' runnings as the brushes bed down and acquire the normal smooth surfaces.
5. Where convenient placement of the aerial is not possible, and the noise level is still objectionable, after ensuring that the above conditions are met with, it may prove necessary to fit an alternative suppression device, such as a larger suppressor condenser or a line filter. Consult your radio technician.

PARTS LIST

(a) Mark DK-J 1.5 K.W. 110 Volt Direct Supply Generator.

(b) Mark DK-K 1.5 K.W. 240 Volt Direct Supply Generator.

(c) Mark DK-L 1.5 K.W. 110 Volt Battery Charging Generator.

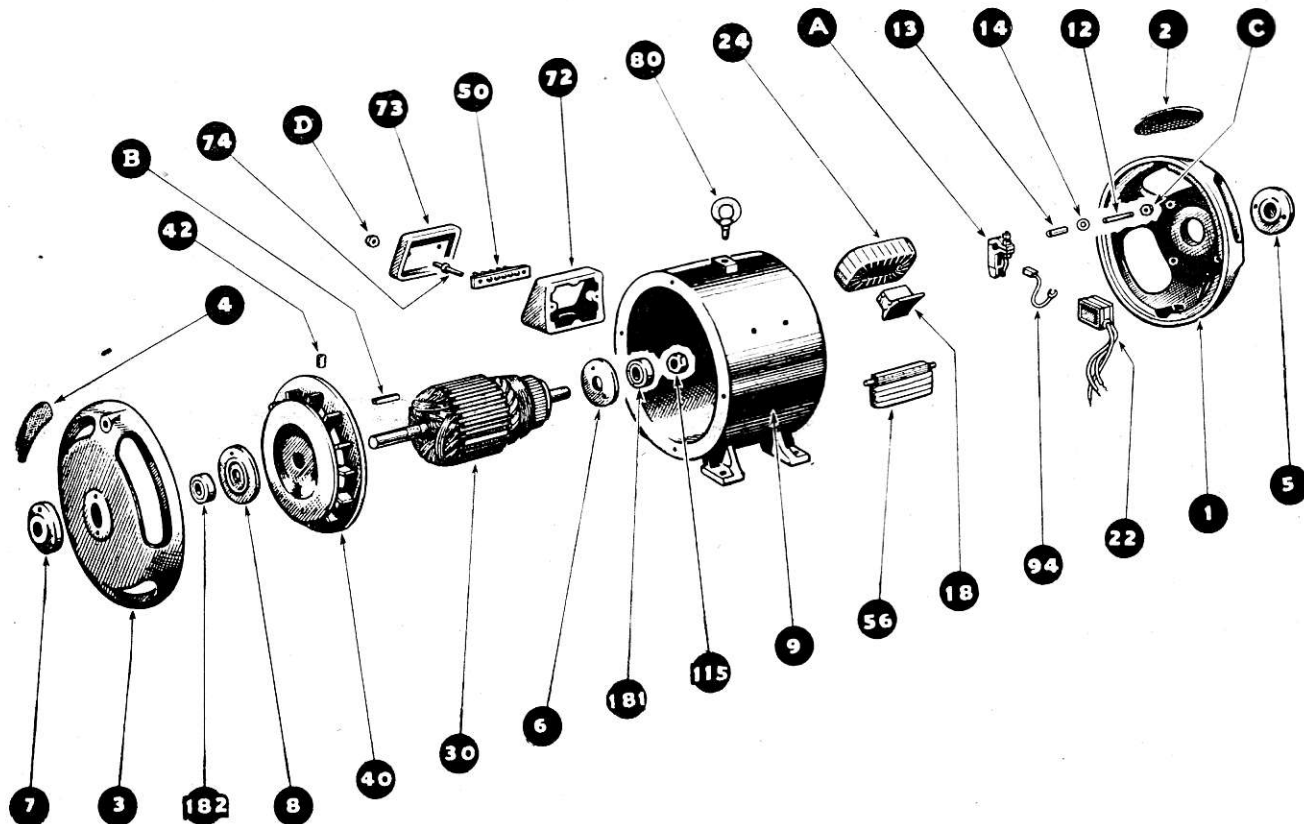

No. off	Sym. No.	Name of Part.
1	DL-G 1	Commutator End Endshield
4	DL-G 2	Commutator End Endshield Cover
1	DL-G 3	Drive End Endshield
4	DL-G 4	Drive End Endshield Cover
1	DL-G 5	Commutator End Outside Bearing Cap
1	DL-G 6	Commutator End Inside Bearing Cap
1	DL-G 7	Drive End Outside Bearing Cap
1	DL-G 8	Drive End Inside Bearing Cap
1	DM-G 9	Body (for Mark DK-J only)
1	DM-K 9	Body (for Marks DK-K and DK-L Generators).
4	DL-G 12	Brush Holder Stud
4	DL-G 13	Brush Holder Insulating Sleeve
4	DL-G 14	Brush Holder Insulating Washer
4	DL-G 18	Main Pole (Marks DK-K and DK-L only).
4	DK-G 18	Main Pole (Mark DK-J only).
1	KN 22	Suppressor Condenser
4	DK-J 24	Field Coils (Mark DK-J Generator only) —2 crossed, 2 straight.
4	DM-K 24	Field Coils (Mark DK-K Generator only) —2 crossed, 2 straight.
4	DM-J 24	Field Coils (Mark DK-L Generator only) —2 crossed, 2 straight.
1	DK-J 30	Armature (Mark DK-J Generator only)
1	DK-K 30	Armature (Mark DK-K Generator only)

No. off	Sym. No.	Name of Part.
1	DM-J 30	Armature (Mark DK-L Generator only)
1	DL-G 40	Fan
1	ZB 42	Fan Locking Screw
1	DM-G 50	Terminal Strip
1	DM-K 51	Terminal Connection Marking Strip (Marks DK-K and DK-L only).
1	DM-G 51	Terminal Connection Marking Strip (Mark DK-J only).
2	DK-L 56	Interpole Assembly (Mark DK-L only).
2	DK-K 56	Interpole Assembly (Mark DK-K only).
1	DM-G 72	Terminal Box
1	DM-G 73	Terminal Box Cover
2	DM-G 74	Terminal Box Stud
1	DM-G 80	Eye Bolt
4	A.O-B 94	Brush
1	AW-D115	Bearing Locknut
1	AO-B181	Commutator End Bearing
1	DL-G182	Drive End Bearing
4	A	Brush Holder (Morgan Crucible MF 62)
1	B	Generator Key (2 1/4 in. x 5/16 in. x 5/16 in. M.S. Parallel Key).
4	C	Brush Holder Stud Locknut (3/8 in. Whit. Nut).
2	D	Terminal Box Cover Nut (5/16 in. whit. Nut).

PARTS LIST

Marks DA-J and DA-K Switchboards for 1.5 K.W. Direct Supply Generating Sets

(Mark DA-J 110 Volt; Mark DA-K 240 Volt)

No. off	Sym. No.	Name of Part.	No. off	Sym. No.	Name of Part.
1	DA-J 1B	Front Panel Assembly	1	DA-J 88	Voltmeter.
1	DA-G 4	Terminal Strip Cover	1	DA-J 89	Ammeter.
1	DA-G 7	Back Panel Assembly	1	DA-G 90	Rheostat Knob.
2	DA-G 10	Side Assembly	1		Rheostat; I.R.C. Power Wound 50 Watt, 450 ohm, Type P.R. 50 (Mark DA-J Switchboard only)
1	DA-G 14	Terminal Strip	1		Rheostat; I.R.C. Power Wound, 50 Watt, 1200 ohm, Type P.R. 50 (Mark DA-K Switchboard only)
2	DA-J 15	Terminal Strip Mounting Bracket			
6	DA-G 16	Terminal Connection			
1	DA-J 18	Terminal Connection Marking Strip			
1	DA-G 41	Rheostat Indicator Plate			
1	KD 74	Main Switch Fuses			

PARTS LIST

Mark DA-L Switchboard for 1.5 K.W. 110 Volt Battery Charging Generating Set

1	DA-L 1B	Front Panel Assembly	1	DA-G 17	Terminal Strip Common Connection
1	DA-G 4	Terminal Strip Cover	1	DA-L 18	Terminal Connection Marking Strip
1	BR-G 5	Starter Push Button Switch	1	DA-G 41	Rheostat Indicator Plate
1	DA-L 7	Back Panel Assembly	1	KD 74	Main Switch and Fuses
7	CR-B 8	Button Insulator	1		Cutout—"University 110V"
2	DA-G 10	Side Assembly	1	DA-L 89	Ammeter.
1	DA-G 14	Terminal Strip	1		Rheostat, I.R.C. Power Wound 450 Ohm, 50 Watt, Type P.R. 50.
2	DA-J 15	Terminal Strip Mounting Bracket	1	DA-G 90	Rheostat Knob.
12	DA-G 16	Terminal Connection			
1	CZ-D 17	Resistance Wire			