

Instruction Manual for...

SOUTHERN CROSS



GENERATING SETS

Fig. 3060 1 K.W. 32 or 50 Volt Battery Charging and Direct Lighting.

Fig. 3090/3091 1.5 K.W. 32 or 50 Volt Battery Charging and Direct Lighting.

Fig. 3067 1 K.W. 32 or 50 Volt Battery Charging and Direct Lighting.

SOUTHERN CROSS GENERATING SETS

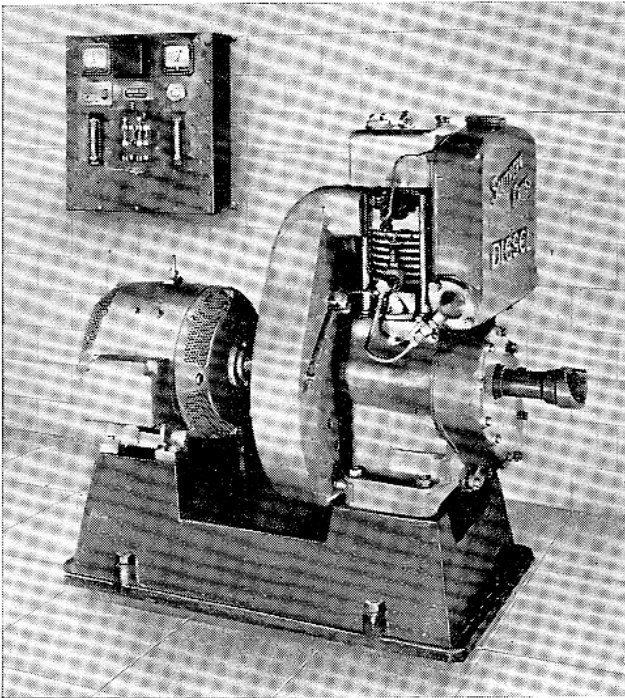

*Fig. 3060—1 K.W. 32 or 50 Volt Battery
Charging or Direct Lighting
Generating Set.*

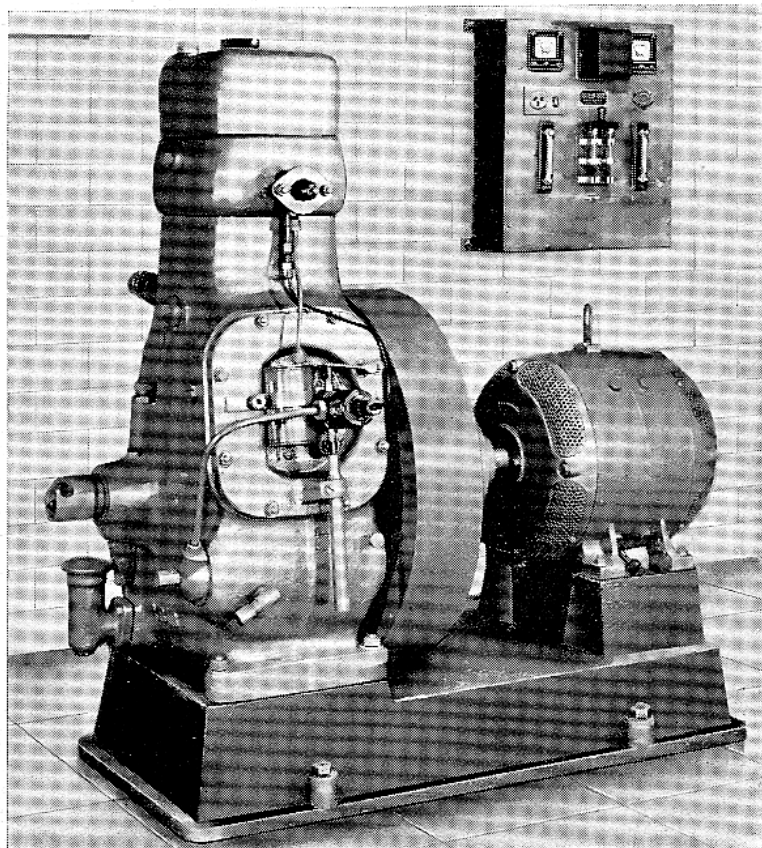

*Figs. 3090/3091—1.5 K.W.
32 or 50 Volt Battery Charging
or Direct Lighting Generating Set.*

Installation of Fig. 3060 1 K.W. and Fig. 3090/3091 1.5 K.W., Generating Sets

Layout of Set

Before starting to install the set, decide on the position for the engine and generator, switchboard and battery. The illustrations below show convenient layouts for the sets. The main points to remember when planning the layout are:

1. The switchboard should be mounted on a wall where it is easily accessible.
2. The battery must not be placed under the switchboard as acid fumes may affect the board.
3. If a shelf is being made to hold a Car or Radio Battery while it is being charged, place it to the side and not under the Switchboard.

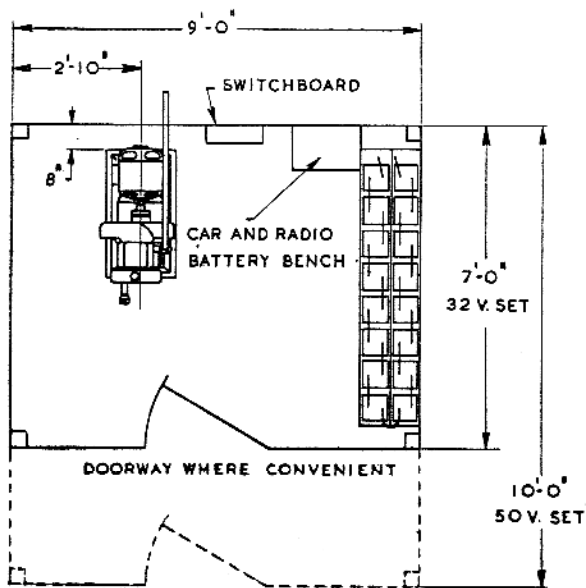

Layout of Fig. 3060 1 K.W. Generating Set

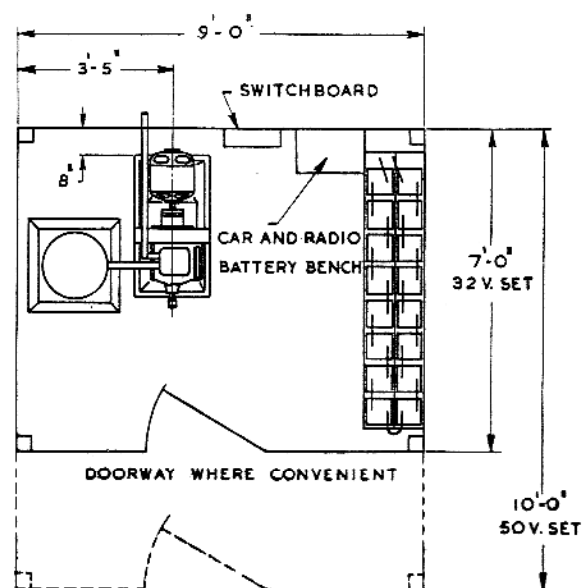

Layout of Fig. 3090 1.5 K.W. Generating Set
(NOTE.—For Fig. 3091 "Radiator Cooled" Set, width of Room may be reduced by 2ft. The distance between the Set and the wall on the Cooling Tank side would then be 2ft. less).

Foundation for Set

To obtain the best results from this set, install it on a firm foundation. A large block of concrete with the foundation bolts set into it, makes a suitable foundation.

To Make Concrete Block

1. After deciding where the set is to be installed, sink a hole in the ground 1ft. to 1ft. 6in. deep and to the sizes on the General Arrangement Illustrations on Page 3. Light soil requires a larger base than heavy, well-packed soil, but always make the block larger for preference.
2. Make a wooden template to hold the foundation bolts in their correct positions while the concrete is being poured. (Refer to Illustrations on Page 4.) Slide the base on to the template and, using a $\frac{1}{2}$ inch bit, mark the positions for the holes. Remove the base and bore $\frac{1}{2}$ inch holes through the template.
3. Place template in position over the hole in the ground. Take the foundation bolts from the engine case, put large washers on them and then hang them from the template so the tops will project $3\frac{1}{4}$ inches above the concrete when the template is removed.
4. Drive in some small pegs around the ends of the crossboards to hold the template in position. Check that the template is level with a spirit level and pack under the ends if necessary.
5. Mix a batch of concrete, using 4 parts sharp stone or rubble, 2 parts sand and one part cement. See that the stone and sand are clean and do not contain any clay or dirt. If they do, wash carefully before mixing. A block 1ft. 6in. deep will require approximately 4 bags of cement, $\frac{1}{2}$ yard of sand and $\frac{1}{2}$ yard of stone.
6. Fill the hole with concrete and at the same time, place old bars and bolts in for reinforcements.
7. Allow the concrete to set for two or three hours and then carefully lift off the template, taking care not to disturb the bolts. If necessary, smooth off the top of the block, using a mixture of 2 parts sand and one part cement. Allow the concrete to set for a day.

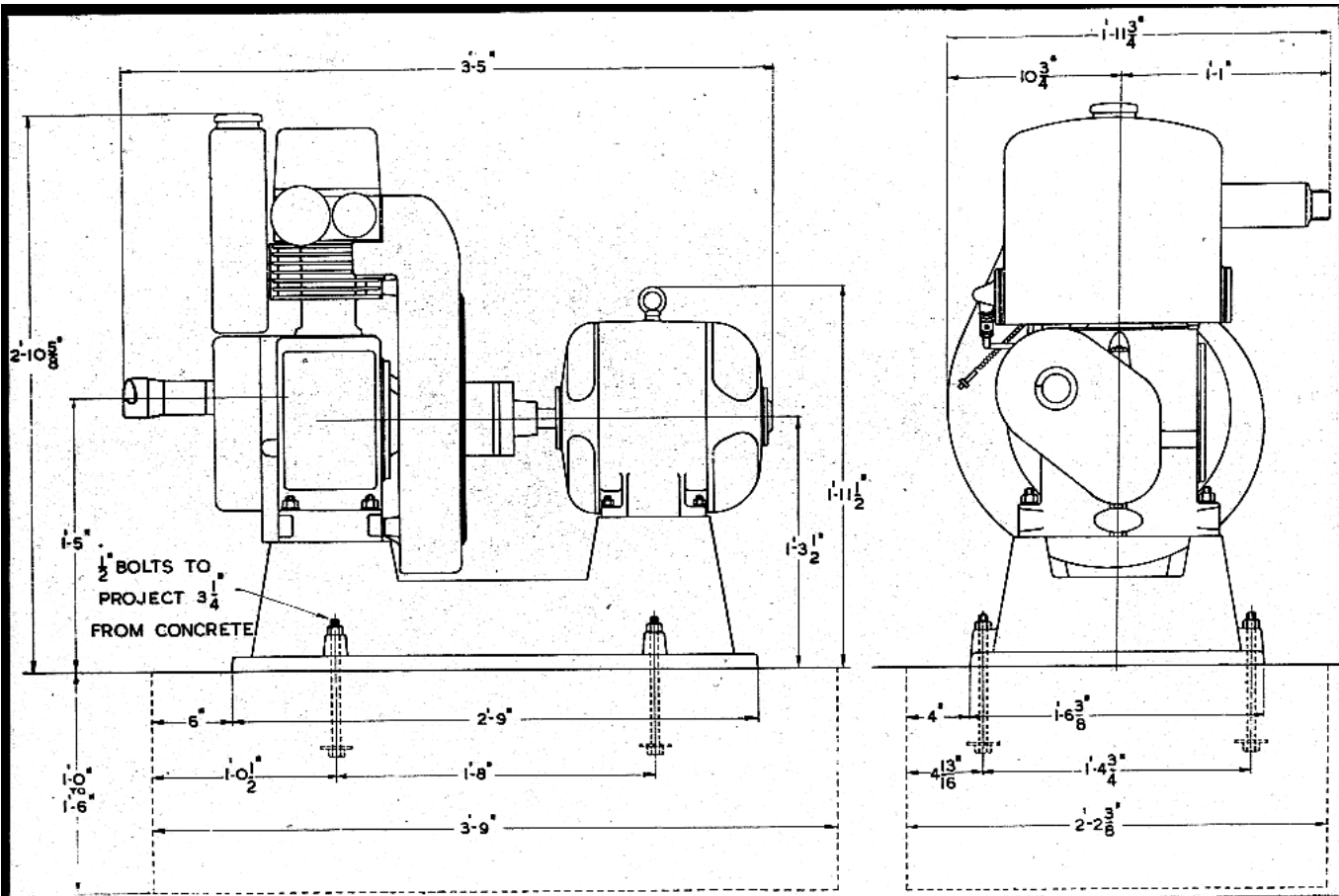

General Arrangement of Fig. 3060 1 K.W. 32 or 50 Volt Generating Set

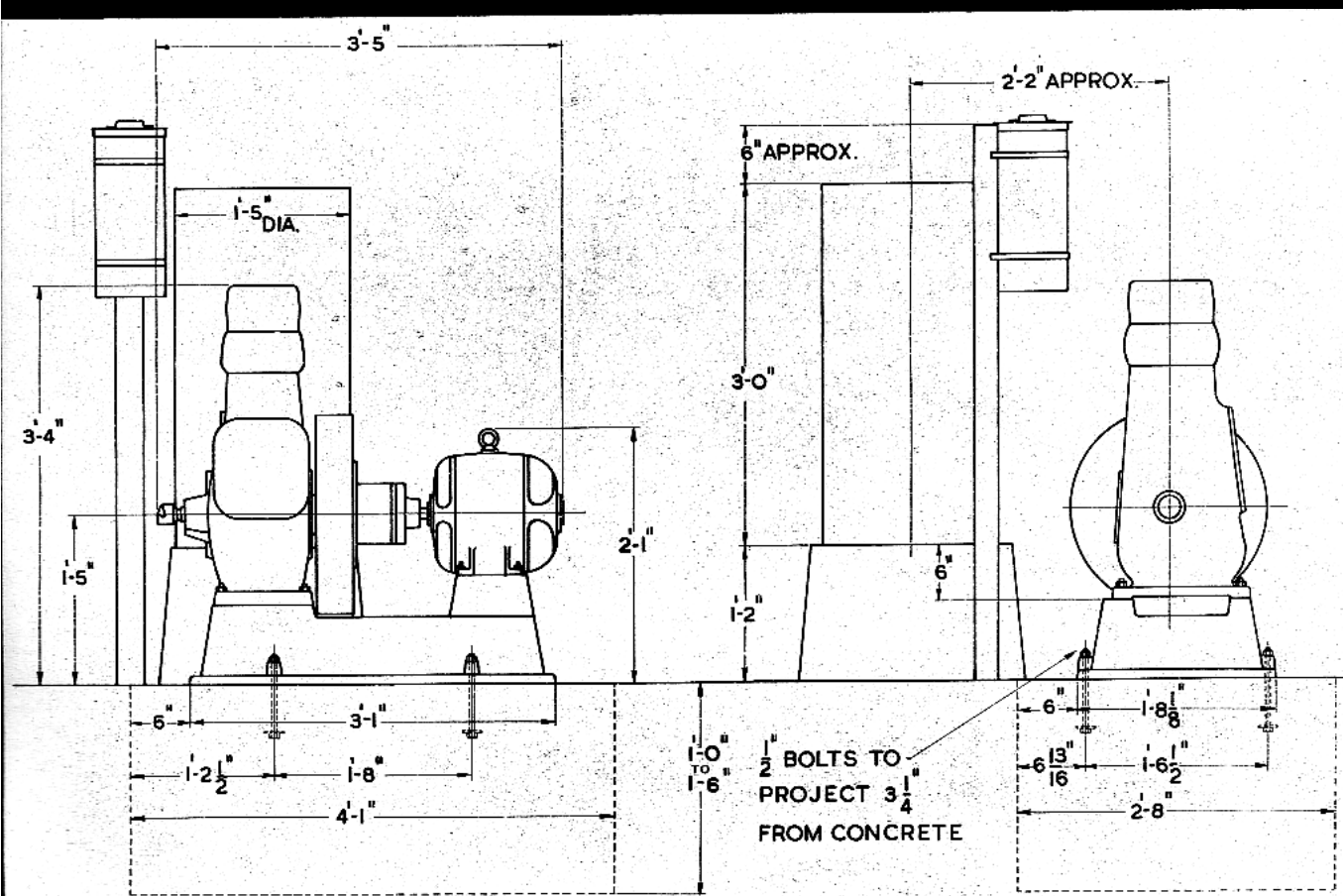

General Arrangement of Fig. 3090 1.5 K.W. 32 or 50 Volt Generating Set

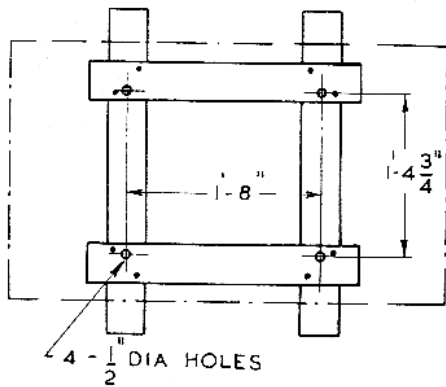

Bolt Template for Fig. 3060 1 K.W.
Generating Set

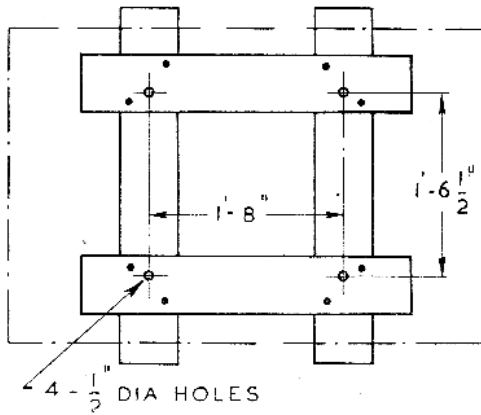

Bolt Template for Fig. 3090/3091 1.5 K.W.
Generating Set

Lining Up The Set

1. Lift the base into position on the concrete block, and with a spirit level, check that the base is level. Where necessary place thin pieces of tin under the edge of the base to level it, and then tighten down the nuts on the foundation bolts.
2. Take the studs supplied in the generator box and screw them into the base, short-threaded end first. To tighten the studs into the base, screw two nuts on to each stud in turn, lock them together, tighten stud using the spanner on the top nut and then unlock nuts.
3. Unscrew the cylinder head cover nut on the engine and screw on the lifting shackle. On the Mark ET-B Diesel engine, lift off the cylinder head cover before screwing the lifting shackle on. Then lift the engine on to the base and replace the cover and cover nut.
4. Clean the face of the engine flywheel and fit the driving half of the flexible coupling. On the Mark ET-B Diesel Engine, screw it on to the engine crankshaft and tighten using the starting handle as a tommy bar. On the Mark Y-B Engine, lock it on with the three setscrews provided.
5. Slide the other half of the coupling on to the generator shaft and see that the key is in position. Fit the coupling disc on to the driving pegs and lift the generator on to the base.
6. The two halves of the coupling are the same diameter so that if the diameters coincide, the engine and generator must be in line. By checking with a straight edge on top, underneath, and on either side,

line up the coupling. The generator can be raised as required, using the packing shims supplied. Take particular care with the lining-up as accuracy is important.

7. When the lining-up is correct, bolt the engine and generator down and re-check the lining up.
8. Shift the driven half of the coupling along the generator shaft so there is 1/64 inch clearance either side between the coupling disc and the coupling halves, i.e., the coupling disc has a total clearance of 1/32 inch. Lock the driven half of the coupling in this position.

Mounting Switchboard on Wall

The Switchboard must be mounted vertically on the wall in a convenient position close to the generating set.

IMPORTANT: Do not mount the switchboard over the battery as the acid fumes may affect it.

Fix suitable bearers of about 3in. x 2in. timber at a convenient height, and then bolt the switchboard to the bearers, using the bolts supplied.

Setting Up the Battery

The generating set has been designed for use with the battery in the engine-room, but the battery may be placed at the house subject to the following conditions:

- (a) The set cannot be used for direct lighting.
- (b) The engine cannot be electrically started.

Although the installation of the battery at the house limits the operation of the set as above, it enables the set to be installed up to 50 per cent. further from the house without an increase in the size of the overhead lines between the house and the set. For this reason, generating sets driven from a Mark YB Diesel Milking Machine Engine usually have the battery at the house. Refer to next section "Wiring Up Set" which shows maximum permissible distance between the set and the house for different size overhead lines.

Make a battery stand similar to the one illustrated, allowing a spacing of 1½ inches between the cells. It is recommended that the stand be painted with acid proof paint.

Connect the cells together, making sure they are connected correctly, that is, positive terminal of one cell to the negative of the next cell. Use the flexible connection between the end cells of the two rows.

Tack the battery instruction chart on the wall behind the battery.

Make a small bracket to support the hydrometer by its bulb, allowing it to hang free without any risk of breaking.

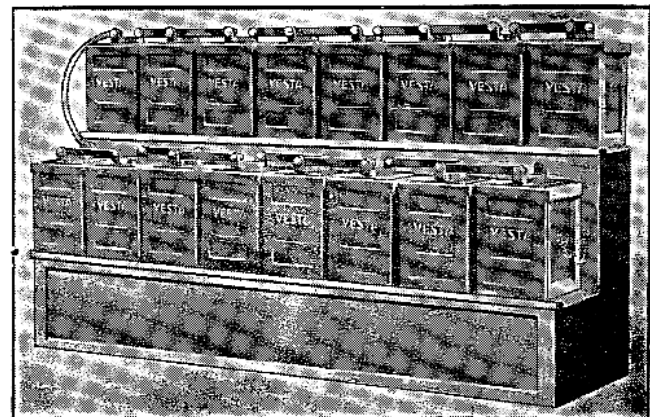

Battery Stand

Wiring Up Set

1. Remove the small panel from the front of the switchboard to expose the terminal strip. Also remove the cover from the generator terminal box.
2. Refer to the wiring diagram at the top of the illustration on Page 6, which shows the necessary connections where the battery is installed in the engine room. For installations with the battery at the house the connections are shown in the wiring diagram on this page.

Use 7/.044 wiring between the Switchboard and Generator and the Switchboard and Battery, if installed in the Engine Room. The connections between the Switchboard and Push Button can be made, using 3/.029 wire. **NOTE: The Push Button should not be placed so there is more than 25 feet of wiring between the Switchboard and Push Button.**

It is recommended that the wiring between the generator and switchboard be run in conduit; and where there is a concrete floor, the conduit can be concreted in if screwed conduit is used. The bottoms of the generator terminal box and the switchboard are drilled for conduit connections. It may be necessary to use a short length of flexible conduit to connect to the generator terminal box. After fitting the conduit, but before joining the pieces together, push a piece of wire through them so that the main connection leads can be pulled through.

Tough Rubber Sheathed Cable (TRS) may be used between the Switchboard and the battery.

The size of the overhead lines to the house will vary according to the distance the set is installed from

the house. The table below shows the maximum distances the generating set, with the battery in the engine room, can be from the house using the different wire sizes, to ensure good lights.

Size of Set		Wire Sizes			
		7/.064	7/.080	7/.092	7/.104
1	K.W. 32 Volt	200ft.	310ft.	410ft.	525ft.
1	K.W. 50 Volt	475ft.	725ft.	1,000ft.	1,250ft.
1.5	K.W. 32 Volt	130ft.	200ft.	275ft.	350ft.
1.5	K.W. 50 Volt	320ft.	500ft.	650ft.	850ft.

NOTE: Where the battery is installed at the house the distances shown may be increased by half.

Earthing: Connect a wire between the terminal marked E on the switchboard terminal strip, and one of the studs which hold the generator terminal box in place. Also continue this wire and connect it to a piece of iron or copper bar driven into the ground outside the building.

The above connection earths only the frames of the switchboard and generator to avoid any possibility of shock should a leak occur. It does not earth either the positive or negative line.

If it is desired to earth the negative line for any reason, this can be done by making the connections shown above and in addition, connecting the common G-, L-, B- terminals to the terminal E on the switchboard terminal strip. Consult the installing electrician about your particular earthing requirements.

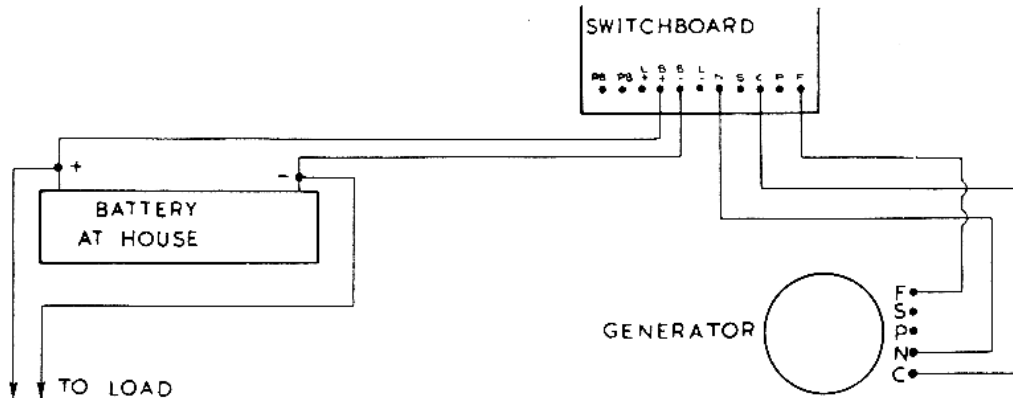

Wiring of Set where Battery is at House

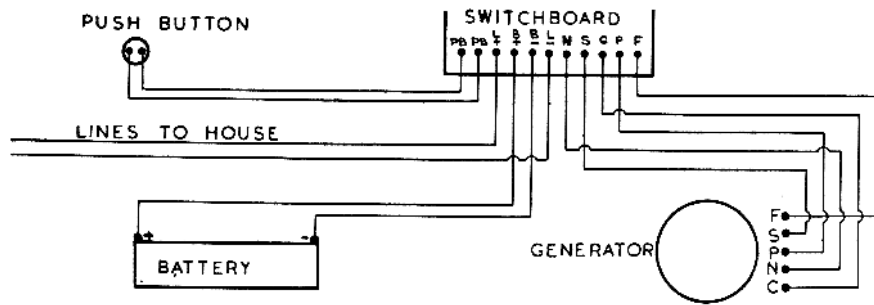

Wiring of Set where Battery is in Engine Room

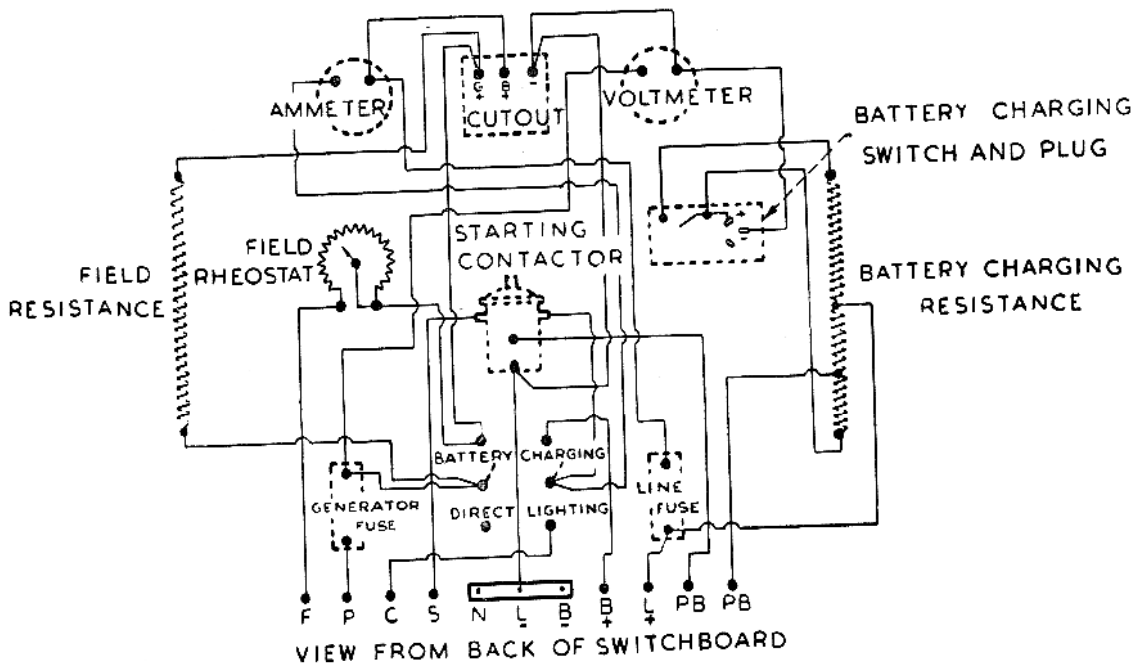

VIEW FROM BACK OF SWITCHBOARD

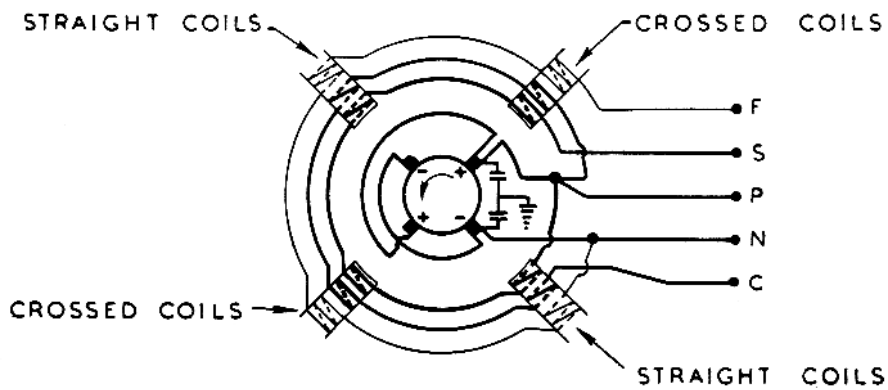

VIEW FROM COMMUTATOR END

Wiring Diagram for Figs. 3060, 3090/3091 and 3067 Generating Sets

Installation of Fig. 3067 1 K.W. Generating Set

(Generator driven by a Mark YB Diesel Engine driving "CO" Pattern Southern Cross Milking Machine)

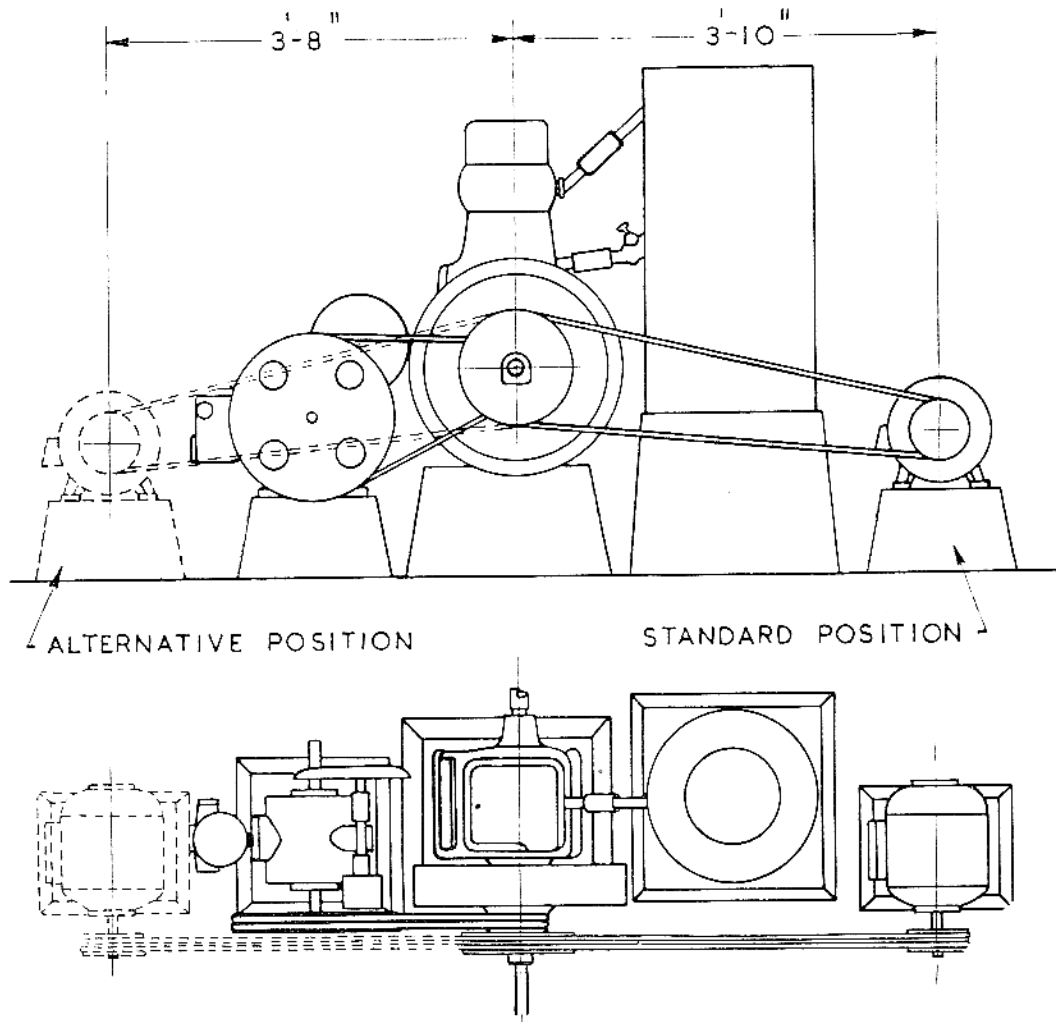

General Arrangement of Fig. 3067 1 K.W. 32 or 50 Volt Generating Set

Layout of Drive

The illustration above shows how the generator drive is made.

The standard position of the generator is behind the engine cooling tank, or in cases of hopper cooled engines, the generator can be moved up closer to the engine. As an alternative position, the generator can be placed out past the vacuum pump, but in this position the moisture trap inlet pipe has to be fitted on the side away from the belt. This is done to avoid fouling the belt drive to the generator.

Foundation

It is recommended that the generator be installed on a concrete block as a firm foundation is important. To make a suitable concrete block, proceed as follows:

1. Construct a wooden mould 9 inches high with 1ft. 2½in. by 9½in. inside dimensions at the top of the mould.
2. Nail two pieces of timber to the top of the mould and sit the generator on top of them. Fit the generator pulley.

3. Bolt the driving pulley to the Mark YB Diesel Engine flywheel pulley with the setscrews supplied.
4. Using a line cord, determine the correct position for the concrete block by lining up the generator pulley with the driving pulley.
5. Lift off the generator and mark the position of the inside of the mould. Remove the mould and sink a hole 12 inches deep.
6. Nail two long pieces of timber to the sides of the mould to support it over the hole and then set it in position.
7. Sit the generator on top of the mould again and line it up, using the line cord as in (4). Also see that the generator is sitting level.
8. Mark the positions for the foundation bolts on the timber crossboards and lift off the generator. Bore $3/8$ inch holes in the crossboards. Place the washers on the foundation bolts and then hang them in the mould so they will project $1\frac{1}{2}$ inches above the top of the concrete block.
9. Mix a batch of concrete, using 4 parts stone, 2 parts sand and one part cement. Fill the mould, putting in some old steel bars or bolts as reinforcements. Be careful not to move the mould.
10. Allow the concrete to set for 24 hours and then remove the mould. Surface the block with a 50/50 mixture of sand and cement.
11. Allow the block to stand for at least another day. Then put the generator in place and tighten it down. Then put on the belts.

For Instructions for Mounting Switchboard on Wall, Setting Up the Battery, and Wiring Up the Set, refer to Pages 4 and 5.

Running Instructions

Operating Switchboard

Knife Switch: There are three different positions for the knife switch. They are (1) Off; (2) Battery Charging and (3) Direct Lighting. Both the "Battery Charging" and "Direct Lighting" positions are marked on the board, and if the switch is not in either of these positions, it is "off."

In the "off" position, the set cannot be electrically started; the battery cannot be charged and load cannot be taken from the battery, i.e., lights, etc., cannot be used at the house.

The switch must be in the "Battery Charging" position for starting the set electrically and for charging the battery.

The "Direct Lighting" position is only used when the battery is not installed or when the battery cannot be used for any reason.

Battery Charging Switch and Plug. This control is provided so that Car and Radio Batteries can be charged when required. Refer to section, "Charging Car and Radio Batteries" on Page 11, which gives instructions for its use.

CONTROL	BATTERY CHARGING POSITION		DIRECT LIGHTING POSITION
	Battery in Engine Room	Battery at House	
Ammeter	Indicates the charge to or discharge from the battery. The readings will vary and depend on: (a) Whether or not the set is charging. (b) The amount of load at the house. (c) Whether or not Car and Radio Batteries are being charged. (d) The setting of the field rheostat (when set is charging).	Indicates the charge to and discharge from the battery, where the discharge is taken from the Switchboard, i.e. (Car and Radio Charging Plug or Line Terminals). Does not indicate main discharge from Battery to house.	Indicates total load on set on the discharge side of the meter.
Voltmeter	When the battery is being charged, the generator voltage must be greater than the battery voltage to give a charging current through the battery. For this reason the voltmeter will show higher readings when used for "Battery Charging" than when used for "Direct Lighting" and these readings will vary with the condition of the battery during charge, i.e., as the battery becomes charged, the voltage will rise. Voltmeter readings are not important and may be disregarded.		Indicates Voltage output of set, which should be: 32 Volt Set, 31 to 33 Volts. 50 V. Set, 49 to 52 Volts. To alter voltage, adjust field rheostat.
Field Rheostat	To increase the charge to the battery, turn the rheostat knob in a clockwise direction and vice versa.		To increase the voltage turn the rheostat knob in a clockwise direction and vice versa.
Fuses (if blown)			
(a) Generator Fuse (right hand fuse)	Generator will still electric start the engine. Battery will supply light. Generator will not charge the battery.	Battery will supply light. Generator will not charge the battery.	Voltmeter will not work but load can be taken from the set.
(b) Line Fuse. (left hand fuse)	Generator will not electric start the engine. Generator will charge the battery. Neither the battery nor generator can supply light.	Car and Radio Battery Charging Plug will not operate.	Voltmeter indicates but no load can be taken from the set.

Speed of Set

The Generator on the Fig. 3060, 3090/3091 and 3067 Generating Sets is designed to run at 1,200 r.p.m. on full load.

The Mark YB Diesel Engine, as supplied, is set to run at 1,200 r.p.m. on full load so it will not be necessary to make any adjustment where the generator is direct coupled to the engine. On Fig. 3067 Generating Sets, the pulley sizes are designed to give the correct generator speed if the Mark YB Diesel Engine is run at the normal speed for driving "CO" Pattern Milking Machines, i.e., 900 r.p.m. for 2, 3 and 4 Unit Plants, and 1,200 r.p.m. for 5 and 6 Unit Plants.

The Mark ET-B Diesel Engine, as supplied, is set to run at 1,500 r.p.m. on full load, so it will be necessary to reduce the speed to 1,200 r.p.m. on load. To do this, refer to section "Engine Speed" in the Engine Instruction Manual. A tachometer should be used to check the speed of the set.

To Start Set

The following procedure applies to sets which can be electrically started from the battery.

Prepare engine for the first run as detailed in the Engine Instruction Manual.

1. See that the fuel cock is on.
2. **Close the knife switch in the Battery Charging position, and turn the field rheostat knob as far as it will go in an anti-clockwise direction.**
3. See that the fuel pump control rod stop is in the running position. (Refer to Engine Instruction Manual). If this is not done the engine will be difficult to start as it will not receive sufficient fuel.
4. Pour sufficient lubricating oil into the starter plug to fill it, then put into cylinder head cover. Two fillings may be necessary in cold weather but never use more than two fillings of oil or pour oil in while the engine is running, otherwise the engine may be damaged.
5. Press push button and as soon as the engine commences to fire, release the push button. If the engine does not commence firing then the instructions for preparing the Engine for first run in the Engine Instruction Manual have not been followed.

NOTE:

- (a) Do not hold the push button closed for more than about thirty seconds at a time.
- (b) After each attempt to start, allow the battery to stand idle for at least one minute while the engine is checked over to see why it did not start.

If a battery is not installed, or if it is installed at the house, the engine must be cranked by hand as detailed in the Engine Instruction Manual.

To Stop Set

Stop engine as detailed in the Engine Instruction Manual.

Output of Generating Set Driven by Milking Machine Engine

The Mark YB Diesel Engine driving a "CO" Pattern Milking Machine, Skim Milk Pump and Separator will be overloaded if the generator has to deliver the full one kilowatt output.

When charging the battery, full output of the generator is only required:

1. When the battery is fully discharged and then only until it is brought up to about three-quarter charge. If the battery is fully discharged, take the belts off the vacuum pump, skim milk pump and separator and run the engine for about two hours to put a charge into the battery.
2. When an excessive load is applied to the set (such as the use of household electrical appliances) and both the battery and generator are supplying the load. In this case, nothing can be done to reduce the load (i.e., discontinue the use of some of the electrical appliances).

On no account run the engine for long periods when the exhaust shows black smoke. This is a sure indication that the engine is overloaded or out of adjustment.

Try to overcome the black exhaust smoke by reducing the charging rate.

If the exhaust still shows black smoke, refer to the section "Overload" in the Engine Instruction Manual for further instruction.

Charging the New Battery

Although the new cells are fully charged when supplied by the manufacturer they may lose some of their charge during the time they are standing before they are installed. Therefore the new battery should be put on charge as soon as possible.

To charge the battery proceed as follows:

1. Read the recommended level for the electrolyte shown on the Battery Instruction Chart and then check each cell. If necessary, add pure distilled water to correct the level.
2. Start set as shown in instructions, "To Start Set."
3. Adjust the field rheostat knob until the charging rate shown on the ammeter rises to the Finish Charging Rate (usually half the normal charging rate) specified on the Instruction Chart supplied with the battery.
4. Charge for one hour and then check the specific gravity of each cell with the hydrometer supplied with the battery. Continue charging until the specific gravity reaches the fully charged specific gravity given on the Battery Instruction Chart. If the charging rate has dropped while charging, reset it and then stop the set leaving the field rheostat knob at the set position.

When Battery should be Charged

Daily checking of the specific gravity of the cells with the hydrometer will show when it is necessary to charge. **Never allow the specific gravity to drop below the recommended recharging figure shown on the Battery Instruction Chart or allow periods between charging to exceed one week.**

When charging does become necessary, proceed as follows:

1. With the field rheostat knob still set as for the first charging, start the set. The ammeter will show a much higher charge than the setting made during the first charging. This is

quite normal and as the battery becomes charged the rate will drop. When the battery is fully charged the rate will have dropped to the recommended Finish Charging Rate.

2. With the field rheostat set as above, it may be found that the rate during the earlier part of the charging may be below the Maximum Charging Rate shown on the Battery Instruction Chart. In this case, adjustment of the rate to the maximum recommended rate will give faster charging.

IMPORTANT: The Maximum Charging Rate must not be exceeded, and when the cells start gassing freely, reduce the rate to the Finish Charging Rate.

3. Charge until the specific gravity rises to the fully charged figure, and then stop the set.
4. **Once every month** continue the charging until the specific gravity of all the cells is up to the fully charged figure. In cases where one or two cells have less charge than the rest it may be necessary to continue charging from one to four hours after the rest are fully charged. While making this extra charge, feel the cells with a bare hand, and if they get noticeably warmer, reduce the charging rate. Take readings of the specific gravity every half hour and charge until the lagging cells stop rising. Where a cell will not come up to full charge it is likely that some fault has developed in the cell. In this case consult the Battery Manufacturer.

DANGER: Keep naked lights away from the tops or the cells, otherwise there may be an explosion.

Charging Car and Radio Batteries

When a car or radio battery requires charging, attach the positive clip on the lead to the positive terminal of the battery, and the negative clip to the negative terminal, and then plug the lead into the board.

IMPORTANT: Do not handle the clips while the lead is plugged into the board, as this could cause a spark which may cause an explosion.

When more than one battery is to be charged, connect them in series (i.e., positive terminal of one to the negative terminal of the other), but it is recommended that the connected batteries should not total more than 18 volts. When more than one battery is being charged at once, the charging rate is reduced and so the batteries will take longer to charge.

The switch alongside the plug is used to select either the "high" or the "low" charging rate. Move switch up for the "low" rate and down for the "high" rate.

The charging rate will vary with the voltage of the batteries being charged and will be approximately as follows:

Voltage of Batteries being Charged	32 Volt Set		50 Volt Set	
	High	Low	High	Low
2 Volts	4	2	2.2	1.1
4 Volts	3.7	1.8	2.1	1.0
6 Volts	3.5	1.7	2.0	1.0
12 Volts	2.7	1.3	1.7	.8
18 Volts	1.9	.9	1.5	.7

Use the "high" charging rate except where the battery manufacturer specifies a slower rate, or where the battery gases excessively indicating that the rate should be reduced.

When Car or Radio Batteries need charging it is best to charge them when the set is running and to pull the charging lead plug out when the set is stopped. If the plug is left in, the car or radio battery will be charged from the lighting battery. This method of charging may

be used if the battery is required urgently, but it is not recommended unless the lighting battery is almost fully charged.

If the knife switch is left in the "Direct Lighting" position when the set is stopped, the Car or Radio Battery will discharge back into the line at a low rate.

Use of Electrical Apparatus

Before using any electrical apparatus in conjunction with this generating set it is necessary to consider the following points:

- (a) Capacity of the Battery in ampere-hours.
- (b) Ampere discharge from battery to operate apparatus.
- (c) Number of hours the apparatus will be in use.
- (d) Need for more frequent recharging of battery.

The battery capacity is the amount of current the battery will produce while discharging and is measured in ampere hours. To obtain the ampere hour capacity, the number of amperes flowing from the battery is multiplied by the number of hours that the current is flowing. This means that for a fully charged battery rated at 210 ampere hour capacity, 21 amperes could be drawn from the battery for 10 hours.

Battery Manufacturers commonly rate their batteries at a certain discharge for 10 hours, and this is called the "10 hour rate."

As a general rule the total rate of discharge from your battery should not be allowed to exceed the "10 hour rate" of your battery.

Where an appliance such as a household iron, or a ½ h.p. electric motor, which causes a high rate of discharge, is to be used for several hours, it is advisable to run the set while using the appliance.

Set out below is a list of some of the electrical apparatus which may be used and the power required to operate it.

Apparatus	Watts	Amps at 32 Volts	Amps at 50 Volts
25 Watt Globe	25	0.8	0.5
40 Watt Globe	40	1.25	0.8
50 Watt Globe	50	1.6	1.0
60 Watt Globe	60	1.9	1.2
75 Watt Globe	75	2.4	1.5
1/16 H.P. Motor	80	2.5	1.6
¼ H.P. Motor	150	4.7	3.0
1/6 H.P. Motor	200	6.2	4.0
½ H.P. Motor	275	8.6	5.5
¾ H.P. Motor	535	16.7	10.7
Sewing Machine Motor	20	0.6	0.4
Washing Machine	200	6.2	4.0
Fan Motor, 9in.	30	0.9	0.6
Fan Motor, 12in.	50	1.6	1.0
Fan Motor, 16in.	60	1.9	1.2
Vacuum Cleaner—Small	120	3.7	2.4
Vacuum Cleaner—Medium	200	6.2	4.0
Soldering Iron	100	3.1	2.0
	200	6.2	4.0
Household Iron	550	17.1	11.0
Toaster	480	15.0	9.6
Radio	60	1.9	1.2
Electric Kettle	500	15.7	10.0
Kitchen Mixer	150	4.7	3.0
Electric Polisher	250	8.0	5.0
Electric Shaver	15	0.5	0.3

Care of the Generator

In order to ensure trouble-free operation of the Generator it is necessary to observe a certain maintenance routine.

Cleaning

Keep all parts of the generator clean. It is most important that the commutator be kept free from dust and dirt. The commutator, brushes, brush holders and spindles, windings and terminals should be periodically wiped down with a clean, dry rag.

Bearings

When the Generator leaves the works the bearings are packed with grease, and do not require further attention before the plant is put into operation.

However, it is advisable to remove the end caps from the bearings about once a year to examine them. The balls and races should be clean and show no signs of rusting. There need only be a smear of grease on the bearing. If necessary, grease should be added to the bearing. Only fill the bearing cage, don't fill the cap with grease, or the bearing will overheat and grease will be forced from the bearing over the windings of the Generator.

The faults from over lubrication of ball bearings are far greater than those occurring from under lubrication. Under no condition must oil or grease containing graphite be used.

Recommended grease is:

Shell Nerita or equivalent.

Brushes

Keep the Brushes free in their holders and all even in pressure. When worn down to less than $\frac{1}{8}$ in. long they should be replaced with new brushes of the size and grade stamped on the name plate.

To Fit New Brushes

1. Remove the covers from the Commutator End End-Shield.
2. Remove the brushes from the holders. Loosen nuts which hold the brush leads to the brush holders and remove them.
3. Try new brushes of the size and grade shown on the name plate in the brush holder.
4. They should slide freely without sticking. If they are tight, ease them down carefully by rubbing the tight side lightly on a flat sheet of fine sand paper until they will just slide in the holder.
5. Put the brushes in the holder and connect the brush leads to the brush holders.
6. Place a piece of sand paper, sand side out, around the commutator, and allow the brushes to seat on the sand paper.
7. Carefully draw the paper backwards and forwards until the brushes assume the correct curvature, taking care to keep it round the commutator so that a flat is not formed in the brush. When the process is nearly completed, fine glass paper should be used to obtain a very smooth finish.
8. After bedding carefully, clean away every trace of dust from the Commutator, Brushes and Holders. Make sure no specks of abrasive material are embedded in the face of the brush.
9. Replace the covers on the endshield and the generator may be started. It is advisable to run it on light load for a few hours before putting on full load to enable the brushes to settle down properly.

Troubles and Their Remedies

A. Sparking at the Brushes

The commutator should be examined occasionally while the plant is running. It should be practically sparkless at all times. If sparking does occur, steps should be taken to cure it or serious trouble may arise in a short time. Sparking may be due to several causes:

1. **Overload of Generator.**
Reduce load and observe whether sparking reduces.
2. **Jumping of Brushes due to Vibration.**
To check for this trouble, proceed as follows: Place a finger lightly on the brush tension arm. If vibration is felt and if the sparking decreases with the added pressure, the sparking is probably caused by vibration. In this case, tighten the screw on the brush holder to increase the tension on the brush.
3. **Brushes not Sliding Freely in the Brush Holder.**
If the Generator is used in dusty conditions the brushes may become jammed in the holders with dust. Remove and clean both holders and brushes.
4. **Wrong Grade of Brushes Being Used.**
Use only the grade of Brush which is specified on the nameplate.
5. **Brush Holders Assembled Wrong Way Around on Spindle.**
Brushes should run directly opposite the centre of the field pole.

B. Generator will not Charge, or Electric Start the Engine

Check the following in order.

1. Make sure there are no loose or dirty connections in the switchboard or between the cells.
2. Check the brushes and make sure they slide freely in their holders. If one brush is not making good contact the efficiency of the Generator is decreased considerably.
3. The right hand fuse looking at the front of the switchboard is connected in series in the charging circuit of the generator. If this fuse is blown, the generator will not charge, but will electric start the engine.
4. If the left hand fuse looking at the front of the switchboard is blown, the generator will not electric start the engine, but the battery can be charged.

C. No Power at House

Check the following in order:

1. The left hand fuse looking at the front of the switchboard is connected in the circuit between the battery and the lines to the house. If the fuse is blown there will not be any power at the house.
2. Knife switch not in "Battery Charging" position or "Direct Lighting" position when set is being run without a battery.

D. Radio Interference

D.C. Generators and motors, when running, cause radio interference, and if this interference is allowed to get into the radio set it may result in so much noise that radio stations become inaudible behind the interference.

Radio interference may be suppressed, but it is almost impossible to completely eliminate it. The greater the degree of suppression required—the more expensive it becomes.

However, interference can be minimized by careful installation. When buying your radio set, get your radio man to suggest the best installation for your particular case.

The following items should be carefully studied before installing your radio, to make sure that interference is minimized.

1. Locate the receiving aerial as far away as possible from the generating plant, and run it at right angles (not parallel) to the power lines from the engine shed to the house, keeping the aerial as high as possible. Use shielded wire from the lead-in to the house right to the set, or use the aerial filters and twin lead-in wires which are available from your radio store. Consult your radio man on this point and use the type of lead-in he recommends.
2. Make sure the generator and switchboard frames are effectively earthed (refer "Earthing," instructions on Page 5).
3. Keep the commutator and brush gear clean. Ensure that brushes are free in their holders and that there is no excessive sparking. Brushes sticking in the holders will spark badly, and will burn away and cause interference.
4. In new installations, it will be found that the noise will lessen over the first few weeks' runnings as the brushes bed down and acquire the normal smooth surfaces.
5. Where convenient placement of the aerial is not possible and the noise level is still objectionable, after ensuring that the above conditions are met with, it may prove necessary to fit an alternative suppression device, such as a larger suppressor condenser or a line filter. Consult your radio technician.

PARTS LIST

Mark DM-G 1/1.5 K.W. 32 Volt Generator and Mark DM-H 1/1.5 K.W. 50 Volt Generator

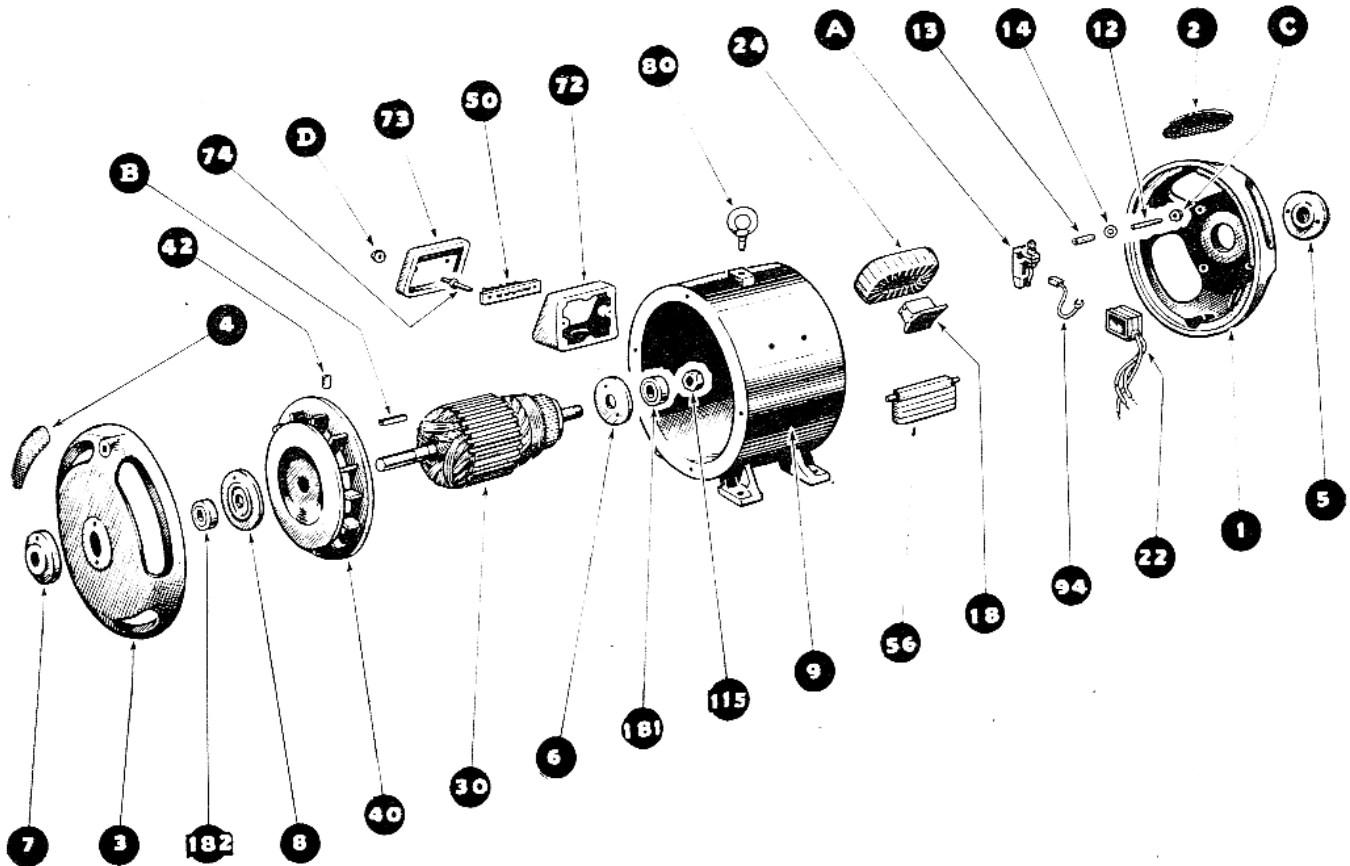

No. off	Sym. No.	Name of Part	No. off	Sym. No.	Name of Part
1	DL-G 1	Commutator End Endshield	1	DL-G 40	Fan
4	DL-G 2	Commutator End Endshield Cover	1	DL-G 42	Fan Locking Screw
1	DL-G 3	Drive End Endshield	1	DM-G 50	Terminal Strip
4	DL-G 4	Drive End Endshield Cover	1	DM-G 51	Terminal Connection Marking Strip
1	DL-G 5	Commutator End Outside Bearing Cap	1	DM-G 72	Terminal Box
1	DL-G 6	Commutator End Inside Bearing Cap	1	DM-G 73	Terminal Box Cover
1	DL-G 7	Drive End Outside Bearing Cap	2	DM-G 74	Terminal Box Stud
1	DL-G 8	Drive End Inside Bearing Cap	1	DM-G 80	Eye Bolt
1	DM-G 9	Body	4	AO-N 94	Brush
4	DL-G 12	Brush Holder Stud	1	AW-D115	Bearing Locknut
4	DL-G 13	Brush Holder Insulating Sleeve	1	AO-B181	Commutator End Bearing
4	DL-G 14	Brush Holder Insulating Washer	1	DL-G182	Drive End Bearing
4	DL-G 18	Main Pole			
1	KN 22	Suppressor Condensor	4	A	Brush Holder (Morgan Crucible Co. MF 63).
4	DM-G 24	Field Coils (MARK DM-G ONLY)—2 crossed, 2 straight.	1	B	Generator Key (2 1/2 in. x 5/16 in. x 5/16 in. M.S. Parallel Key)
4	DM-H 24	Field Coils (MARK DM-H ONLY)—2 crossed, 2 straight.	4	C	Brush Holder Stud Locknut (3/8 in. Whit. Locknut)
1	DM-G 30	Armature (MARK DM-G ONLY)	2	D	Terminal Box Cover Nut (5/16 in. Whit. Nut)
1	DM-H 30	Armature (MARK DM-H ONLY)			

PARTS LIST

Mark DA-G Switchboard (for 1/1.5 K.W. 32 V. Generating Sets) and
 Mark DA-H Switchboard (for 1/1.5 K.W. 50 V. Generating Sets)

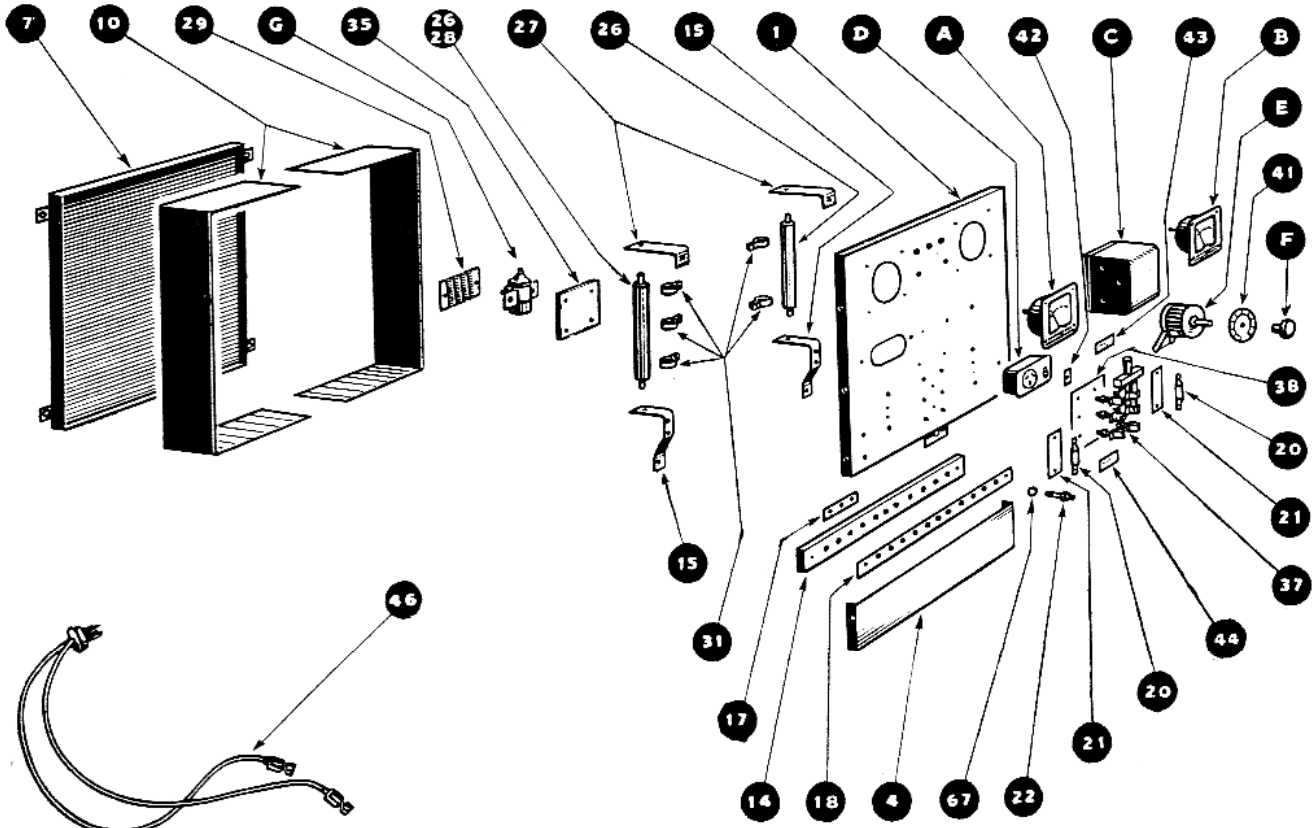

No. off	Sym. No.	Name of Part
1	DA-G 1	Front Panel Assembly
1	DA-G 4	Terminal Strip Cover
1	DA-G 7	Back Panel Assembly
2	DA-G 10	Side Assembly
1	DA-G 14	Terminal Strip
2	DA-G 15	Terminal Strip Mounting Bracket
1	DA-G 17	Terminal Strip Common Connection
1	DA-G 18	Terminal Connection Marking Strip
2	DA-G 20	Fuse
2	DA-G 21	Fuse Mounting Strip
4	DA-G 22	Fuse Connection
2	DA-G 26	Field Limiting Resistance (1) Radio Battery Charging Resistance (1) (MARK DA-G ONLY)
1	DA-H 26	Field Limiting Resistance (MARK DA-H ONLY)
2	DA-G 27	Field Limiting Resistance Mounting Bracket
1	DA-H 28	Radio Battery Charging Resistance (MARK DA-H ONLY)
1	DA-G 29	Starting Contactor Resistance (MARK DA-G ONLY)
1	DA-H 29	Starting Contactor Resistance (MARK DA-H ONLY)
5	DA-G 31	Resistance Clip
1	DA-G 35	Starting Contactor Insulating Panel
1	DA-G 37	Knife Switch
1	DA-G 38	Knife Switch Insulating Panel

No. off	Sym. No.	Name of Part
1	DA-G 41	Rheostat Indicator Plate
1	DA-G 42	Radio Battery Switch Nameplate
1	DA-G 43	Change Over Switch Nameplate for Bat- tery Charging
1	DA-G 44	Change Over Switch Nameplate for Direct Lighting
1	DA-G 46	Battery Connection Leads
4	KC 67	Fuse Insulating Washer
1	A	Voltmeter (University S3 0-75 Moving Coil Type)
1	B	Ammeter (University S3 50-0-50 Mov- ing Coil Type)
1	C	Cutout (University 32V for 32V Set) (University 50V for 50V Set)
1	D	Switch and Plug Combination (Ring Grip No. 85 10 Amp. 240 V.)
1	E	Rheostat (I.R.C. 75 Ohms 50 Watt Type PR50 for Mark DA-G) (I.R.C. 125 Ohms 50 Watt Type PR50 for Mark DA-H)
1	F	Rheostat Knob (Marquis MIK 2/F for 1/2 in. Dia. Shaft)
1	G	Starting Contactor (Nasco 12 Volt Automotive Type)
1		Starter Push Button Switch (Federal 506F).

Electric Starting of Set.

The small plunger which projects from the front panel of the switchboard immediately above the knife switch may be used for the electric starting of the set. The push button should normally be used, but where it is installed some distance away from the set, the pressing of this plunger provides an alternative means of electric starting.